

1. MOUNTING

NOTICE

Do not apply paint, anti-corrosive sealant or contact spray to coating or plastic parts of the equipment.

Those items contain organic solvents that can damage coating and plastic parts, especially plastic connectors.

1.1 How to Install the Antenna Unit(s)

1.1.1 GPS antenna unit (GPA-017S), GNSS antenna unit (GPA-022S)

Install the GNSS antenna unit referring to the outline drawing at the back of this manual.

When selecting a mounting location for the antenna, keep in mind the following points.

- Select a location out of the radar beam. The radar beam will obstruct or prevent reception of the GNSS satellite signal.
- There should be no interfering object within the line-of-sight to the satellites. Objects within line-of-sight to a satellite, for example, a mast, may block reception or prolong acquisition time.
- Mount the antenna unit as high as possible to keep it free of interfering objects and water spray, which can interrupt reception of GNSS satellite signal if the water freezes.
- Referring to the drawing at the back of this manual, leave sufficient space between all antennas to avoid mutual interference.

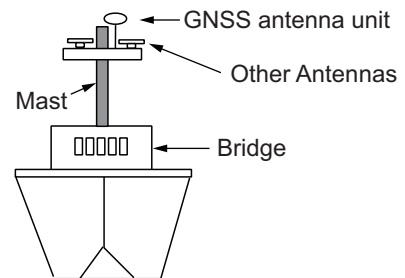

How to extend the antenna cable

Three types of antenna cable extensions are optionally available.

a) Antenna cable set CP20-02700

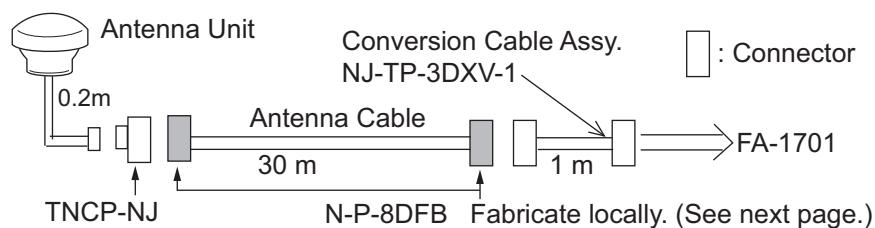

- Securing and waterproofing the connector
Referring to the figures in section 2.2.1 secure and waterproof the connections.
- b) Antenna cable set CP20-02720 (8D-FB-CV, 40m)/CP20-02710 (8D-FB-CV, 50m)
Connect the cable the same as a) above.

1. MOUNTING

c) Cable type RG-10/UY (shipyard supply)

Note: The length of this cable should be less than 20 m to prevent signal loss. The coax. coupling cable assy. (type: NJ-TP-3DXV-1, code no. 000-123-809-10), coaxial connector (N-P-8DFB; supplied), vulcanizing tape and vinyl tape are required. Fabricate both ends of the cable as shown in the figure on the next page.

How to attach the connector N-P-8DFB for cable 8D-FB-CV

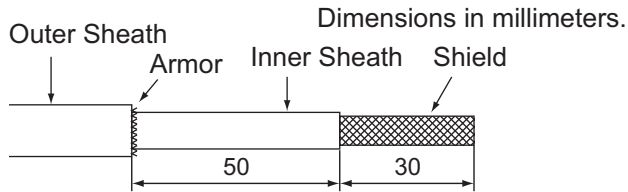

Remove outer sheath and armor by the dimensions shown left.
Expose inner sheath and shield by the dimensions shown left.

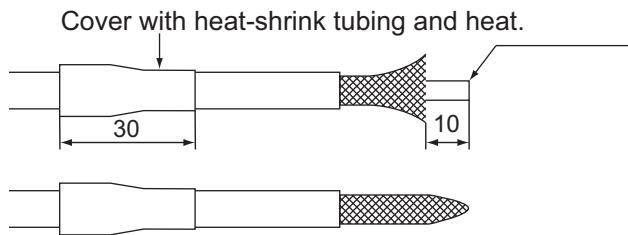

Remove insulator and core by 10 mm.

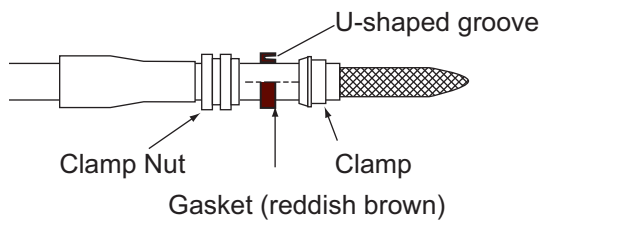

Twist shield end.

Slip on clamp nut, gasket and clamp as shown left.

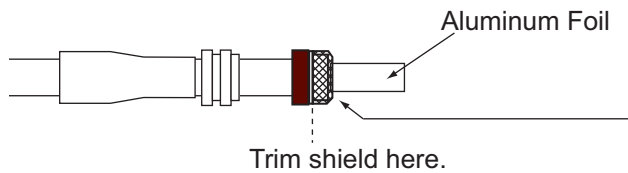

Fold back shield over clamp and trim.

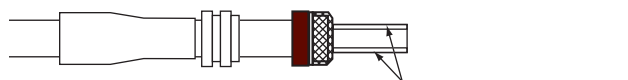

Cut aluminum foil at four places, 90° from one another.

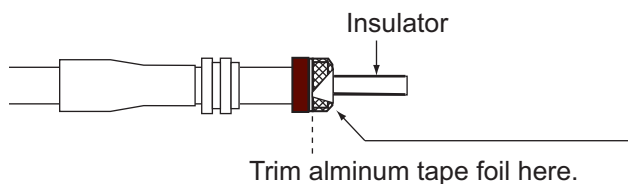

Fold back aluminum tape foil onto shield and trim.

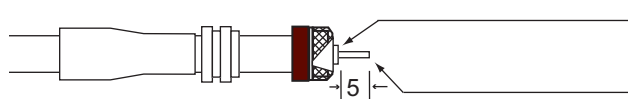

Expose the insulator by 1 mm.

Expose the core by 5 mm.

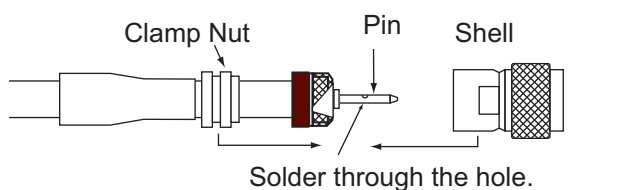

Slip the pin onto the conductor. Solder them together through the hole on the pin.

Insert the pin into the shell. Screw the clamp nut into the shell.
(Tighten by turning the clamp nut. Do not tighten by turning the shell.)

1.1.2 VHF antenna

Requirements for the antenna

Select a good quality antenna that meets the requirement listed below:

- Frequency range: 155 to 164 MHz
- Impedance: 50 ohms
- Polarization: Vertical
- Handling power: 30W
- VSWR: Less than 1.5 (157 to 159 MHz)
- Quality: Able to withstand the marine environment

Installation location

The location of the mandatory AIS VHF-antenna should be carefully considered. Digital communication is more sensitive than analog/voice communication to interference created by reflections in obstructions like masts and booms. It may be necessary to relocate the VHF radiotelephone antenna to minimize interference effects.

To minimize interference effects, the following guidelines apply:

- The AIS VHF antenna should be placed in an elevated position that is as free as possible with a minimum of 0.5 meters in the horizontal direction from constructions made of conductive materials. The antenna should not be installed close to any large vertical obstruction. The objective for the AIS VHF antenna is to see the horizon freely through 360 degrees.
- The AIS VHF antenna should be installed safely away from interfering high-power energy sources like radar and other transmitting radio antennas, preferably at least 3 meters away from and out of the transmitting beam.
- There should not be more than one antenna on the same plane. The AIS VHF antenna should be mounted directly above or below the ship's primary VHF radiotelephone antenna, with no horizontal separation and with a minimum of 2.8 meters vertical separation. If it is located on the same plane as other antennas, the distance apart should be at least 10 meters.

Cabling

- The cable should be kept as short as possible to minimize signal attenuation. Coaxial cables equal to or better than RG10U/Y are recommended.
- All outdoor-installed connectors on coaxial cables should be fitted with preventive isolation such as vulcanizing tape to protect against water penetration into the antenna cable. Also, apply marine sealant at the antenna base to prevent water intrusion from the screw part of antenna base.
- Coaxial cables should be installed in separate signal cable channels/tubes and at least 10 cm away from power supply cables. Crossing of cables should be done at right angles (90°). The minimum bend radius of the coaxial cable should be 5 times the cable's outer diameter.

1. MOUNTING

- Install the VHF whip antenna referring to the outline drawing at the back of this manual. Separate this antenna from other VHF radiotelephone antennas as shown below to prevent interference to the FA-170.

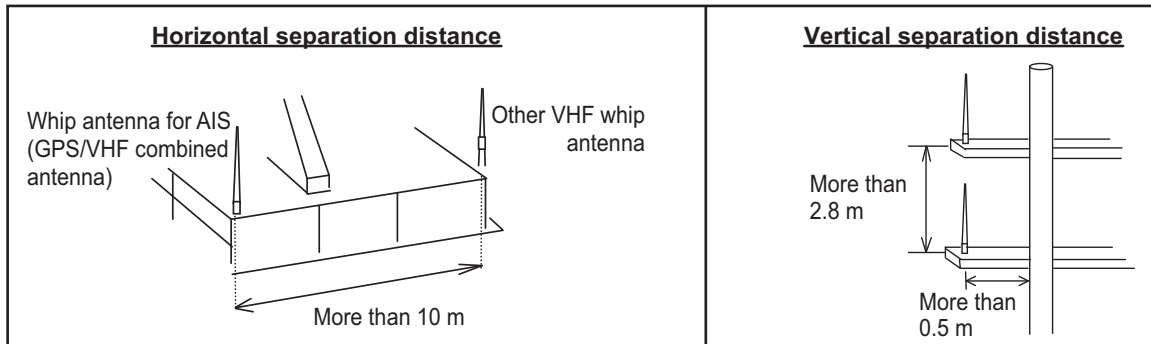

When coaxial cable RG-10/UJ (shipyard supply) is used, attach the coaxial plug M-P-7 (dockyard supply) as shown on the following page.

How to attach the plug M-P-7

Lay the coaxial cable and attach an M-type plug (if necessary) to the cable as follows.

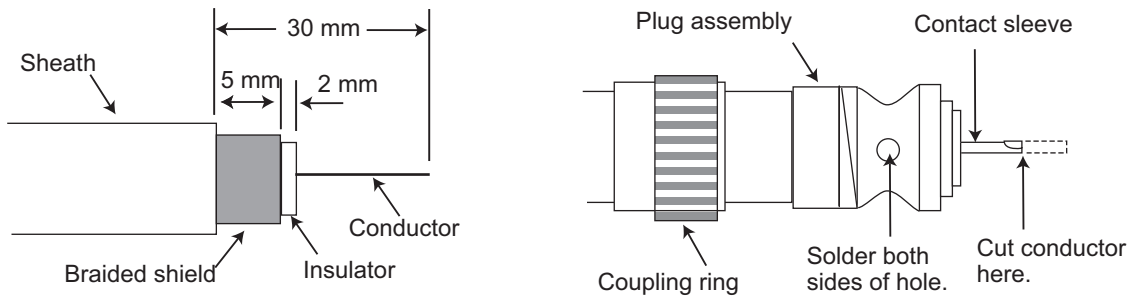

1. Remove the sheath by 30 mm.
2. Bare 23 mm of the center conductor. Trim braided shield by 5 mm and tin.
3. Slide coupling ring onto cable.
4. Screw the plug assembly on the cable.
5. Solder plug assembly to braided shield through solder holes. Solder contact sleeve to conductor.
6. Screw coupling ring into plug assembly.

1.1.3 GNSS/VHF combined antenna (GVA-170), GPS/VHF combined antenna (GVA-100-T)

Install the combined antenna unit referring to the outline drawing. When selecting a mounting location for the antenna, keep in mind the following points.

- Select a location out of the radar beam. The radar beam will obstruct or prevent reception of the GNSS satellite signal.
- There should be no interfering object within the line-of-sight to the satellites. Objects within line-of-sight to a satellite, for example, a mast, may block reception or prolong acquisition time.
- Mount the antenna unit as high as possible. Mounting it this way keeps it free of interfering objects and water spray, which can interrupt reception of GNSS satellite signal if the water freezes.

- Also, refer to the antenna installation guidelines on page 1-3.

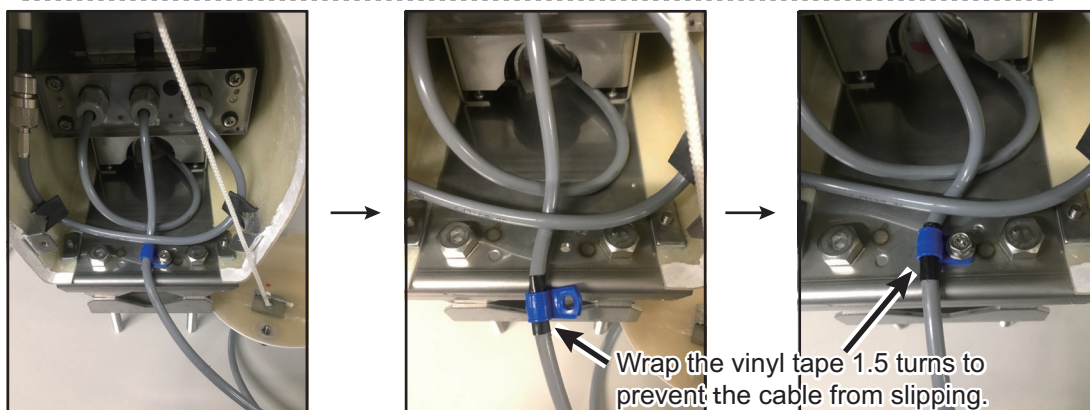
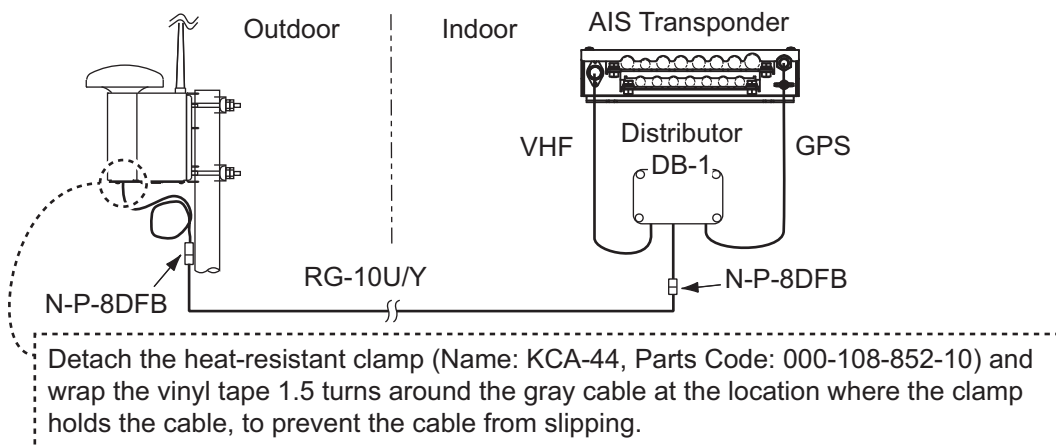

Installation overview of GNSS/VHF combined antenna

Note: Where the mast on which the antenna is installed has a diameter of 60 mm to 80 mm, the optional mast installation kit is required (Model: OP24-5, Code: 005-954-510).

Installing the VHF antenna CX4-3/FEC to the combined antenna GVA-170/GVA-100-T

The compatibility of VHF antenna (CX4-3/FEC) with the GVA-100-T differs with GVA-100-T's serial number.

Compatibility of CX4-3/FEC and GVA-100-T

Serial No.	CX4-3/FEC
000101 to 019999	NG
020000 and after	OK

To install the VHF antenna CX4-3/FEC to the combined antenna GVA-170/GVA-100-T (with serial number 020000 and after), follow the below procedures.

1. Unfasten the upset head bolts (M5, 4pcs.) at the back side of the GVA-170/GVA-100-T.

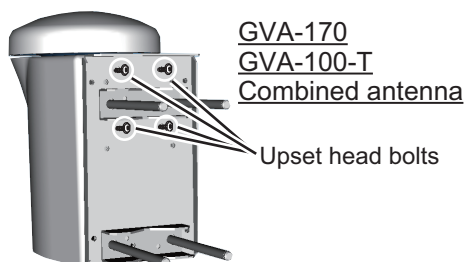

1. MOUNTING

2. Turn the GVA-170/GVA-100-T upside-down, then unfasten three screws with captive washers (M4, 3pcs.) on the bottom cover to detach it.

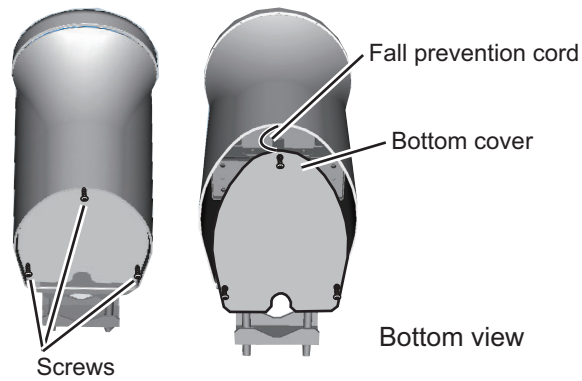

3. Remove the cushioning material from the connector of the cable (MP-3D-360) to connect with VHF antenna.

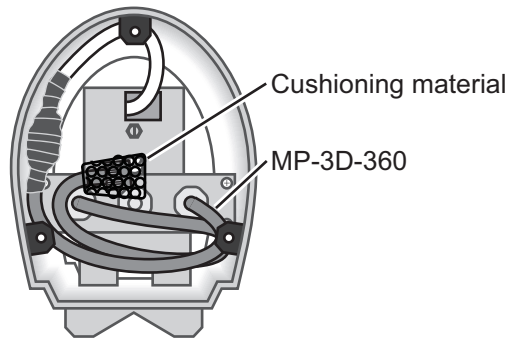

Bottom view after opening the bottom cover.

4. Insert the CX4-3/FEC to the GVA-170/GVA-100-T from the connector side.

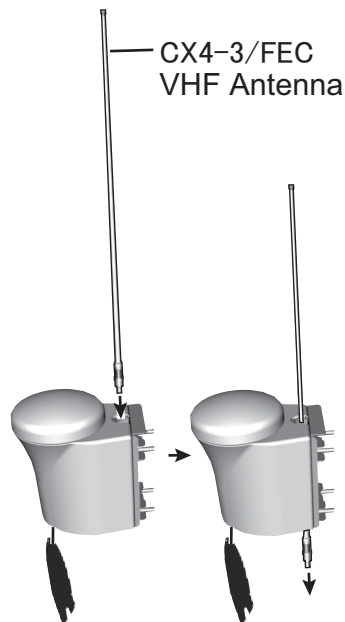

- Connect the MP-3D-360 connector to the VHF antenna and wrap the junction of the connectors with self-vulcanizing tape and vinyl tape.

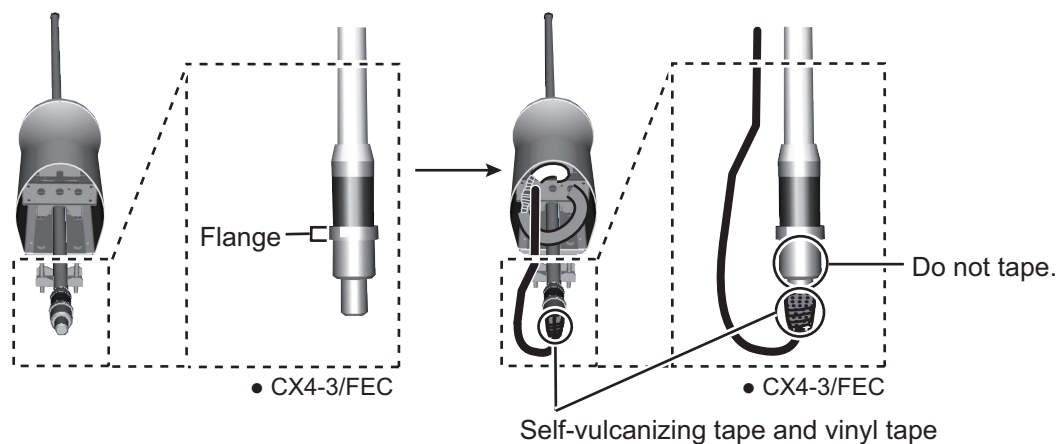

- Raise the CX4-3/FEC upward, confirm that the flange fits the caulking and tighten with the upset head bolts unfastened with step 1.

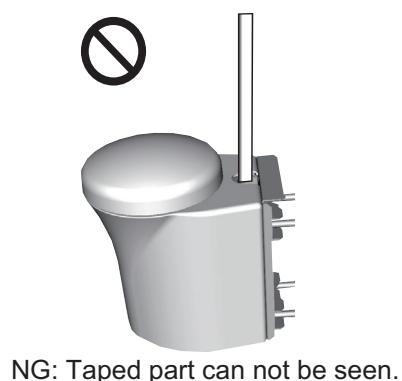
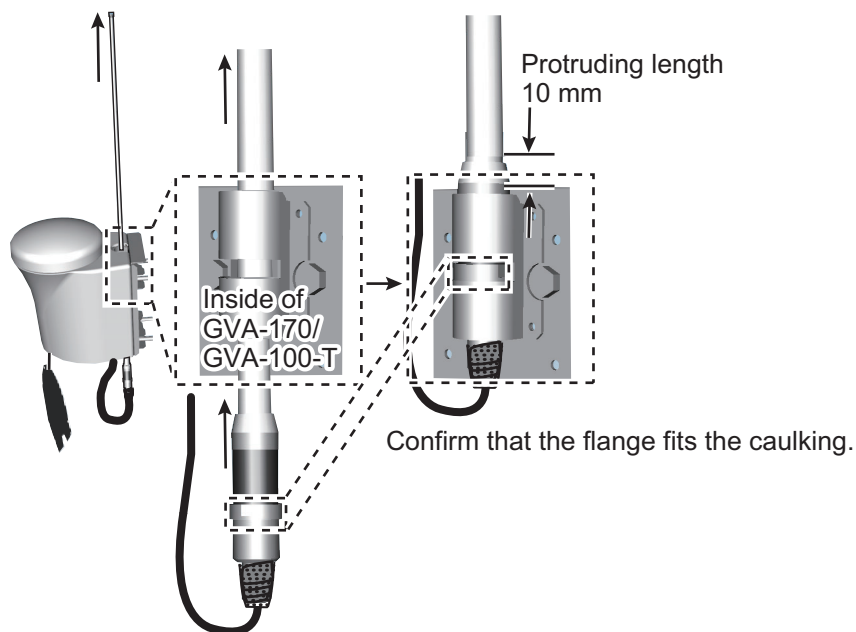

1. MOUNTING

7. Fasten the bottom cover to the GVA-170/GVA-100-T.

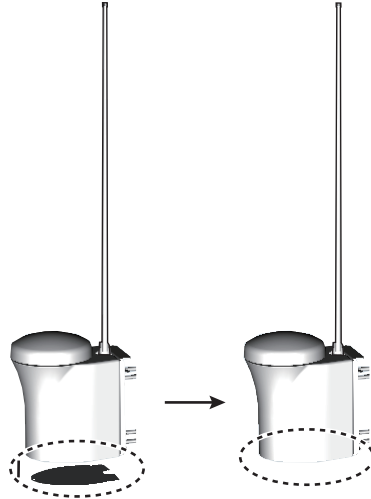

Mounting procedure

1. Dismount the bottom cover, cut the cable-tie inside the unit and take out the coaxial connector attached to the combined box.
2. Loosen four screws to loosen whip antenna fixture and pull out the coaxial connector coming from the combined box through the hole in the whip antenna fixture.
3. Connect the coaxial connector to the whip antenna base and wrap the junction part of the whip antenna with vulcanizing tape and then vinyl tape for waterproofing.
4. Insert the whip antenna from the top of the combined antenna.
5. Secure the whip antenna with whip antenna fixture.
6. Using a new cable tie (supplied), secure the cables and coaxial connector inside the antenna case.
7. Mount the bottom cover.
8. Fix the GNSS/VHF combined antenna to the ship's stanchion (40 to 50 mm diameter) with antenna fixing brackets, flat washers and hex nuts.

Note: Coat the exposed parts of bolts and nuts with marine sealant (local supply).

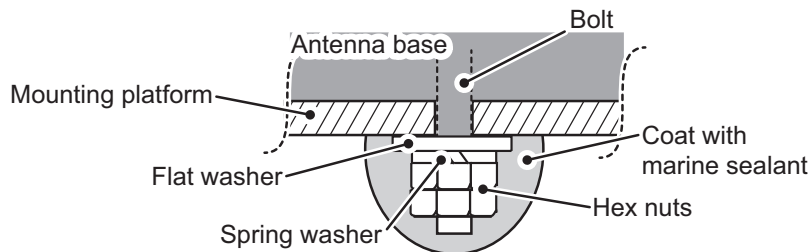

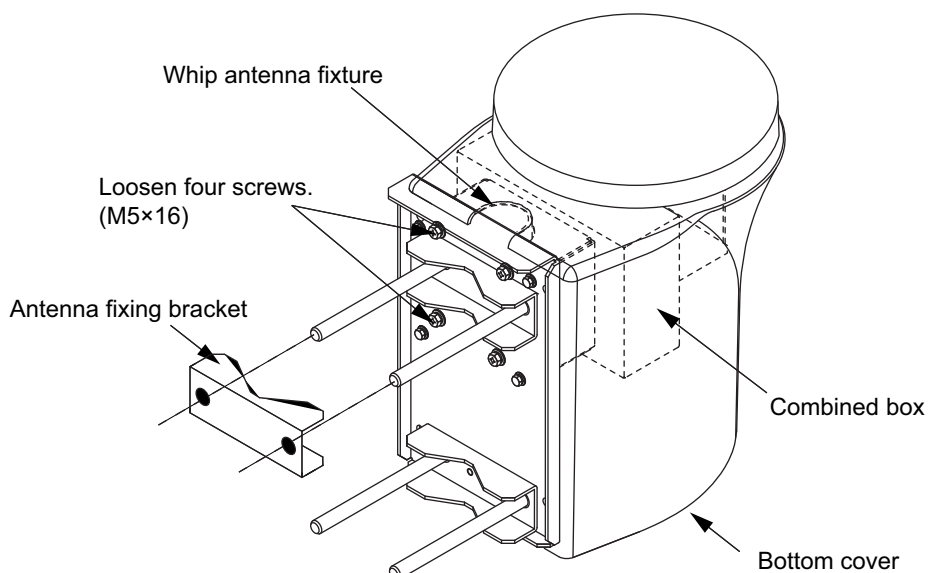

GNSS/VHF Combined antenna, GPS/VHF Combined antenna

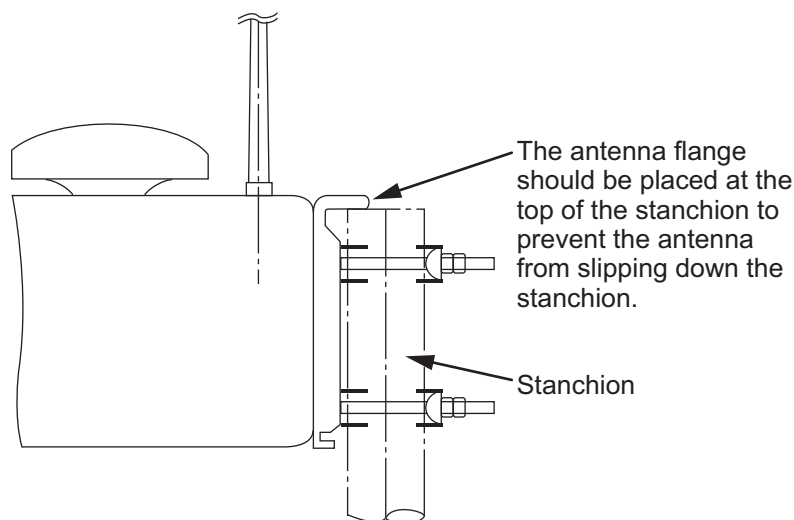

How to install distributor unit DB-1

The length of the cable between the distributor unit and transponder unit is 1 m so locate the distributor unit within 1 m from the transponder unit. Fix the distributor unit on the bulkhead, facing the cable entrance downward. Remove the lid of the distributor unit and secure the unit with two self-tapping screws.

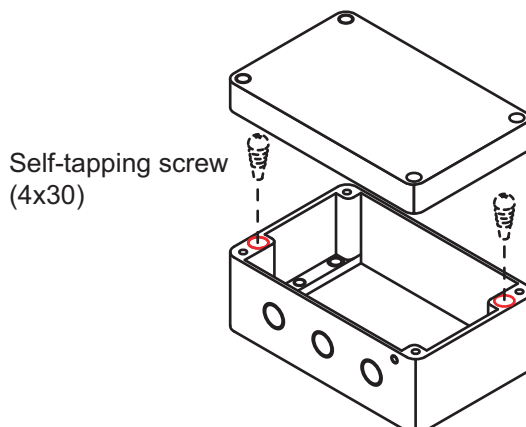

Note: Be sure no foreign material or water enters the distributor unit.

1.2 How to Install the FA-1702 Monitor Unit

The monitor unit can be installed on a desktop, overhead (bulkhead) or flush mounted in a panel. Install it on the chart table or near the steering place, referring to the outline drawing.

When selecting a mounting location for the monitor unit, keep the following in mind:

- Keep the unit out of direct sunlight.
- The temperature and humidity should be moderate and stable.
(Operating temperature range: -15°C to +55°C)
- Locate the unit away from exhaust pipes and vents.
- The mounting location should be well ventilated.
- Mount the unit where shock and vibration are minimal.
- Keep the unit away from electromagnetic field generating equipment such as motor, generator.
- For maintenance and checking purposes, leave sufficient space at the sides and rear of the unit and leave slack in cables. Refer to the outline drawing.
- A magnetic compass will be affected if the unit is placed too close to it. Observe the following compass safe distances to prevent disturbance to the magnetic compass:
Standard compass: 0.65 meters
Steering compass: 0.40 meters
- For flush mount installation, make sure the mounting location is flat.
- To avoid damage to the cabling when mounting the FA-1702, make sure the cabling is not excessively bent.

Note: The cabling to the FA-170 should be completed before mounting the unit. See "How to connect the FA-1702 monitor unit" on page 2-5.

1.2.1 How to fit the cable gasket (When using the OP05-146-1 or OP05-146-2)

When using the cable assembly OP05-146-1 or OP05-146-2, its waterproofing capability can be increased by attaching the cable gasket attached to the cable assembly.

The cable gasket needs to be attached to the cable as shown below. The cut line must face downward to prevent the water intrusion to the unit.

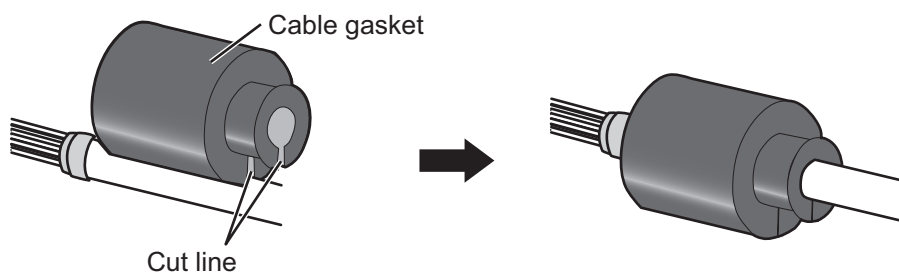

Regarding how to fit the cable gasket to the cable clamp, refer to the illustration on the next page, step 2.

Regarding how to connect the cabling to the FA-1702, referring to section 2.3.1.

1.2.2 How to fit the optional waterproofing kit (OP05-139)

The optional waterproofing kit (OP05-139) must be fitted at the same time as the cabling is connected to the FA-1702.

The waterproofing kit (OP05-139) contains the following items:

- Cover gasket (Code:100-403-800-10) ×1
- Cable gasket (Code:100-403-791-10) ×1

1. Unfasten the four screws on the rear cable clamp, then remove the cable clamp to reveal the WAGO connector.
2. Fit the cable gasket to the cable clamp, referring to the figure below.

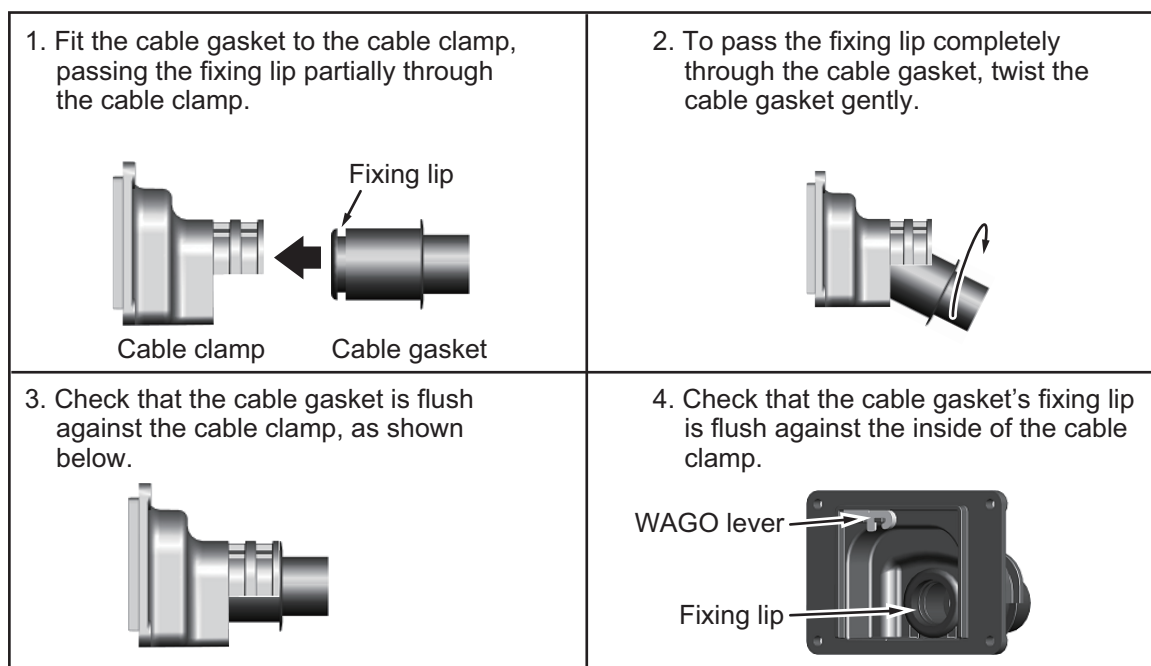

3. Pass the cabling through the cable gasket and cable clamp.
Note: To maintain the IPx5 waterproof rating, the cable must be TTYCSLA-4 (or equivalent) with a diameter of $\phi 14.4 \pm 0.4$ mm.
4. Fit the cover gasket to the rear of the FA-1702. Make sure the cover gasket is placed inside the groove indicated in the figure below.



5. Connect the cabling to the FA-1702, referring to section 2.3.1.

1. MOUNTING

- Slide the cable clamp along the cable until the clamp is flush against the rear of the FA-1702.

Note: The cable clamp must be oriented with the dome-side up, to prevent water intrusion.

- Fasten the four screws removed at step 1.
- Secure the cabling to the cable clamp with cable ties (included) referring to the figure in section 2.3.1.

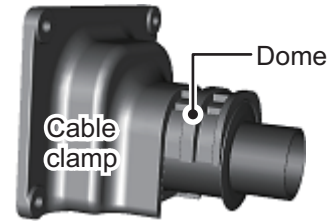

1.2.3 How to install the FA-1702 on a desktop or overhead

The monitor unit is shipped with the hanger. For correct installation, the monitor unit and the hanger need to be separated during the installation.

- Place the monitor unit on a firm, flat surface, then unfasten the two knobs on either side of the monitor unit to separate the monitor unit and a hanger.
- Drill four holes for the self-tapping screws ($\phi 5 \times 20$) at the installation location.
- Secure the hanger to the desktop or overhead with four self-tapping screws ($\phi 5 \times 20$, installation material). The hanger should be oriented with the insertion slots facing forward. For mounting dimensions and required clearance, see the outline drawing at the back of this manual.

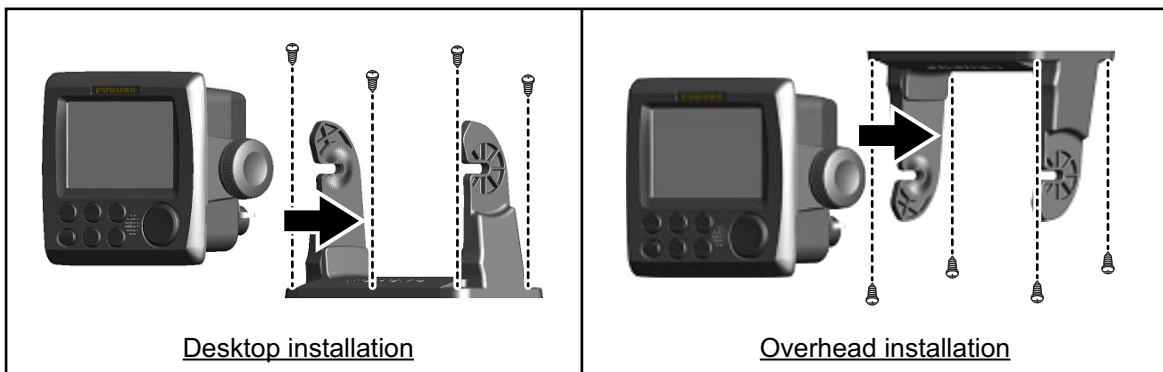

- Referring to section 2.3.1, connect the cabling to the monitor unit.
- Fit the monitor unit to the hanger and tighten the bolts on either side evenly. Adjust the angle of the monitor unit so that the screen can be viewed clearly.

1.2.4 How to flush mount the FA-1702

There are two methods for flush mounting the monitor unit, flush mounting the monitor unit directly to the installation location or with using the optional front fixing panel kit.

Flush mounting the monitor unit (unit only)

1. Cut a hole in the installation location, using the template at the back of this manual.
2. Drill four holes for the self-tapping screws ($\phi 3 \times 20$).
3. Place the monitor unit on a firm, flat surface, then unfasten the two knobs on either side of the monitor unit to separate the monitor unit and a hanger. The hanger can be disposed.
4. Gently lift the locking tabs at the rear of the front panel, then the remove the front panel. Be careful not to damage the locking tabs or the front panel.

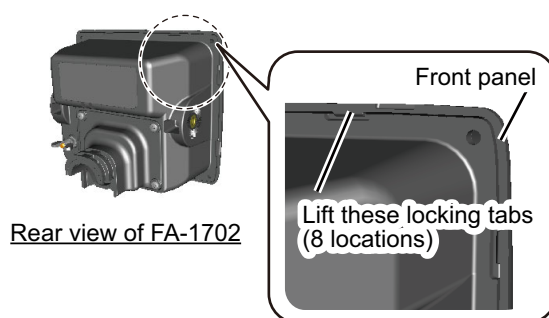

5. Fit the F Mount Cushion (20-032-106, installation material) to the rear of the monitor unit or to the installation hole.
6. Run the cabling through the cutout, then, referring to section 2.3.1, connect the necessary cabling to the FA-1702.

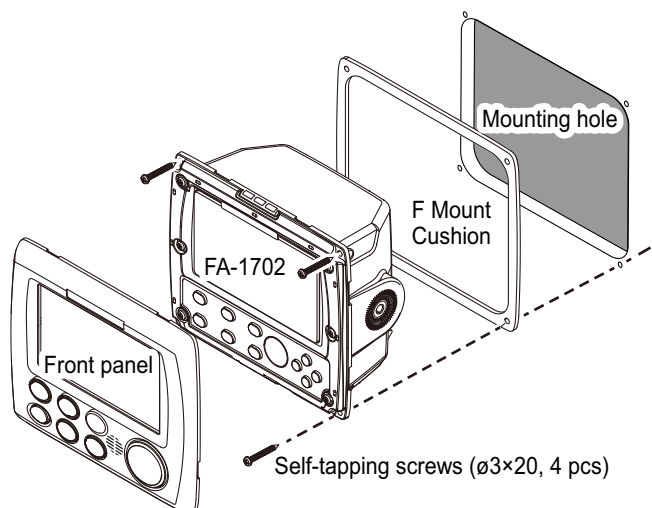

7. Referring to the figure above, fit the FA-1702 to the cutout, then use the supplied self-tapping screws ($\phi 3 \times 20$) to secure the FA-1702 to the flush mount panel.

Flush mounting the FA-1702 (with optional front fixing panel kit)

Use the optional kit (OP24-35), referring to the outline drawings at the back of this manual and the installation instructions (C42-01310) included with the optional kit.

1.3 How to Install the FA-1701 Transponder Unit

Mount the transponder where it is protected from rain and water splash. This unit can be installed on a bulkhead, wall or on the floor. Install it referring to the outline drawing at the back of this manual for dimensions.

When selecting a mounting location for the transponder, keep the following in mind:

- Keep the transponder out of direct sunlight.
- The temperature and humidity should be moderate and stable.
(Operating temperature range: -15°C to +55°C)
- Locate the unit away from exhaust pipes and vents.
- The mounting location should be well ventilated.
- Mount the unit where shock and vibration are minimal.
- Keep the unit away from electromagnetic field generating equipment such as motor, generator.
- For maintenance and checking purposes, leave sufficient space at the sides and rear of the unit and leave slack in cables. Refer to the outline drawing.
- A magnetic compass will be affected if the unit is placed too close to it. Observe the following compass safe distances to prevent disturbance to the magnetic compass:
 - Standard compass: 1.70 meters
 - Steering compass: 1.10 meters
- Avoid floor mounting the transponder in locations where there is water splash. Keep the cable entry away from water spray and splash.

Mounting

1. Select a mounting location, referring to the recommendations listed above.
2. Referring to the outline drawing at the back of this manual, fit two self-tapping screws at the location for the bottom fixing holes. Leave approximately 5 mm of thread exposed.
3. Place the FA-1701 on the two screws.
4. Fasten two self-tapping screws to the top fixing holes.
5. Fasten all screws to secure the FA-1701.

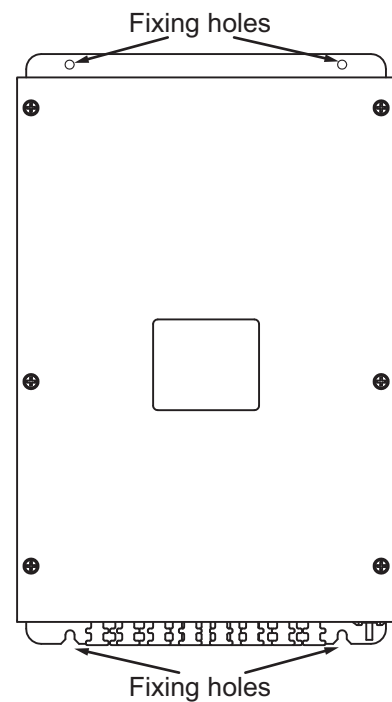

1.4 How to Install the FA-1703 Pilot Plug Unit (option)

The pilot plug unit is only available in the flushmount configuration and should be mounted near where the pilot steers the ship. This plug is used to connect a PC to display AIS information for use by the pilot.

1. Cut a mounting hole in the mounting location, referring to the outline drawing at the back of this manual for mounting dimensions.
2. Feed the necessary cables through the cutout, then referring to chapter 2, connect the pilot plug unit.
3. Set the pilot plug unit to the cutout. Use caution to prevent damage to cables when setting the pilot plug unit into the cutout.

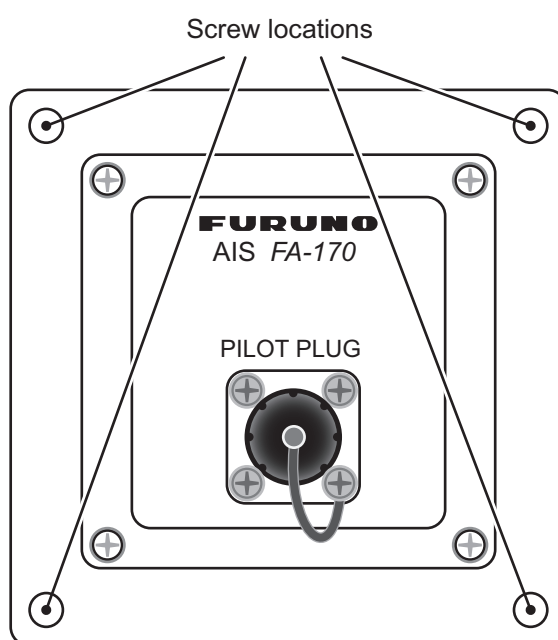
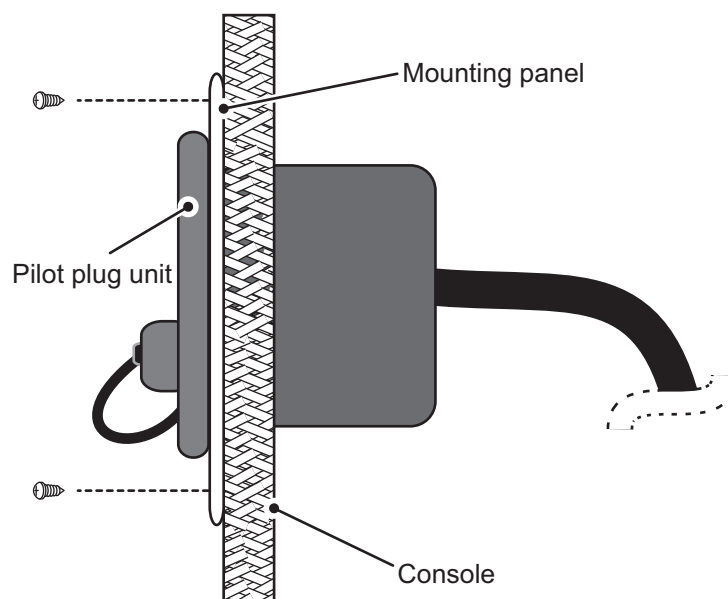

4. Secure the pilot plug unit in place with the supplied screws, referring to the figures above.

1.5 How to Install the PR-241/PR-240 Power Supply (option)

When selecting a mounting location for the unit, keep the following in mind:

- Keep the unit away from areas subject to water splash.
- Locate the unit away from exhaust pipes and vents.
- The mounting location should be well ventilated.
- Mount the unit where shock and vibration are minimal.
- A magnetic compass will be affected if the unit is placed too close to it. Observe the following compass safe distances to prevent disturbance to the magnetic compass:

When using the PR-241	Standard compass: 0.85 meters Steering compass: 0.55 meters
When using the PR-240	Standard compass: 0.90 meters Steering compass: 0.60 meters

Fix the unit with four self-tapping screws (4×16) to a desktop or the deck as shown in the figure below. It is not necessary to open the cover.

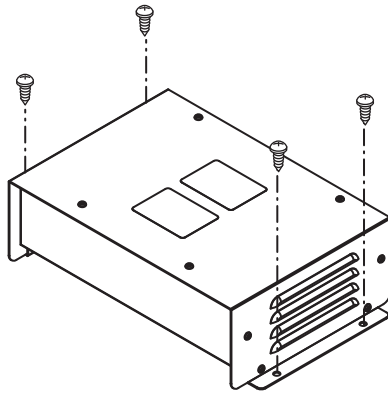

PR-241

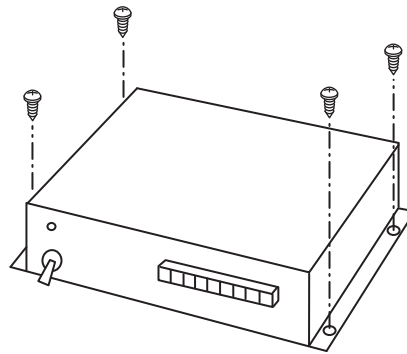

PR-240

2. WIRING

2.1 Connection Overview

Connect the equipment, referring to the interconnection diagram at the back of this manual.

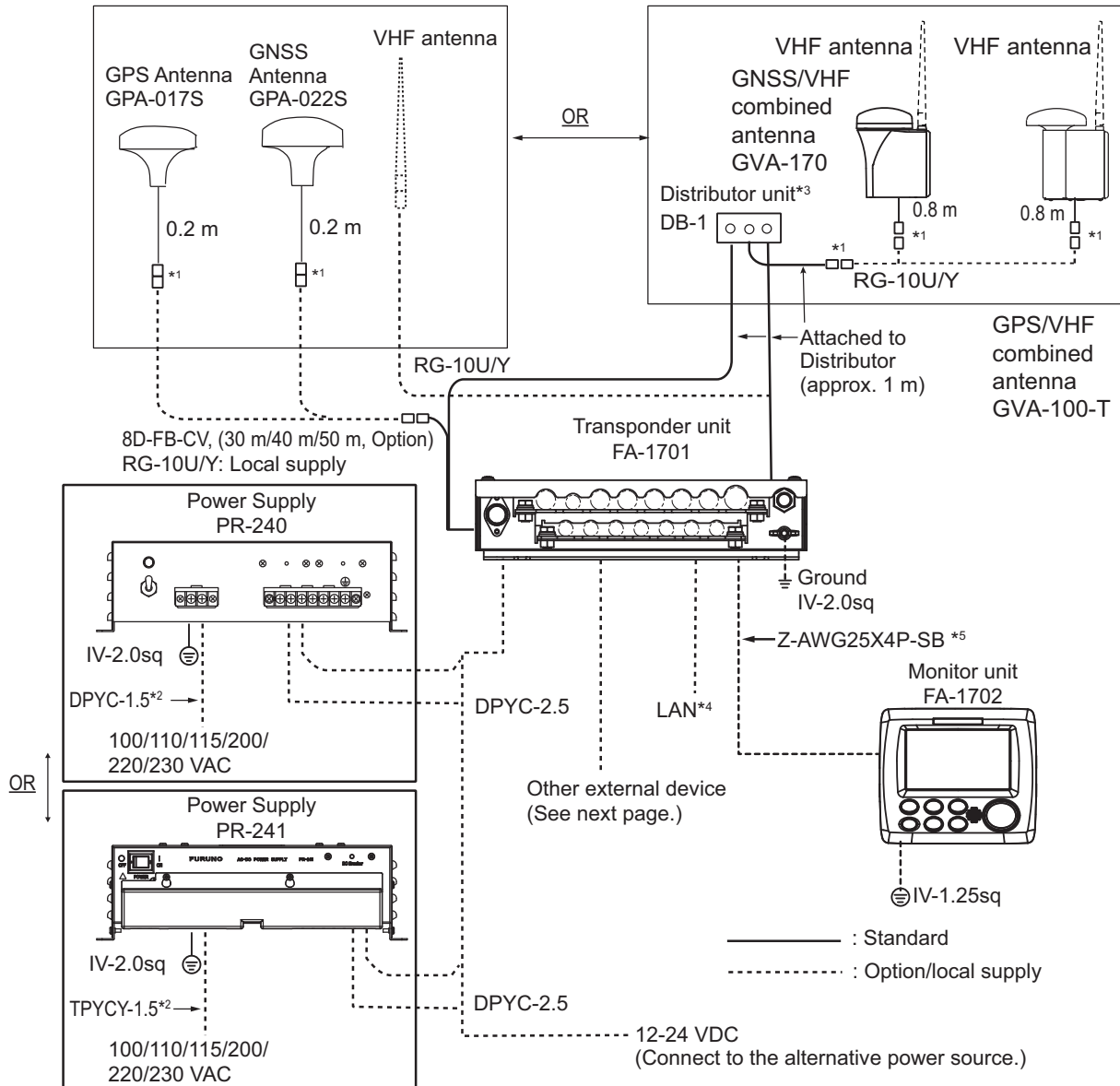

Power supply specifications	
Transponder Unit	12-24 VDC, 6-3 A
Monitor Unit	12 VDC, 0.3 A max.
AC/DC Power Supply Unit	100-115/200-230 VAC, 1 phase, 50/60 Hz

- *1: Connections must be waterproofed. See "How to secure and waterproof exposed connections" on page 2-3.
- *2: DPYC-2.5, TPYCY-1.5, TTYCSLA-1, TTYCSLA-1Q, TTYCSLA-4 and TTYCSLA-7 are Japan Industry Standard cables. Use them or the equivalents, referring to the "JIS CABLE GUIDE" on page AP-1.
- *3: Ground is not required.
- *4: When connecting the LAN cable, leave approx. 200 mm slack before clamping the cable at the cable clamps.
- *5: Cable type varies depending on configuration. Z-AWG25X4P-SB cable may be substituted for TTYCSLA-4 type cable or locally supplied cable.

2.2 How to Fabricate the Cables

LAN cable fabrication

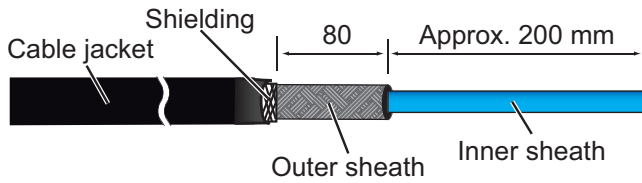

Expose the inner and outer sheaths as shown to the left.



Cover the cable jacket at the cut as shown to the left.

Cover the cable jacket with insulated tape (20 mm width)



1 Expose inner vinyl sheath.

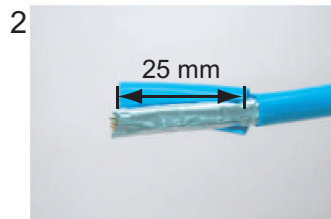

2 Remove the outer sheath by approx 25 mm. Be careful not to damage inner shield and cores.

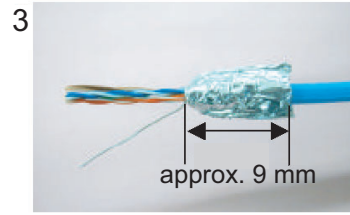

3 Fold back the shield, wrap it onto the outer sheath and cut it, leaving 9 mm.

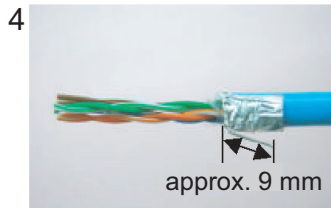

4 Fold back drain wire and cut it, leaving 9 mm.

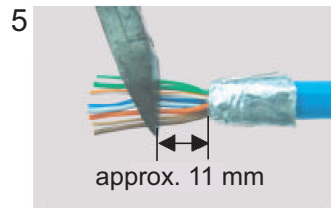

5 Straighten and flatten the cores in order then cut them, leaving 11 mm.

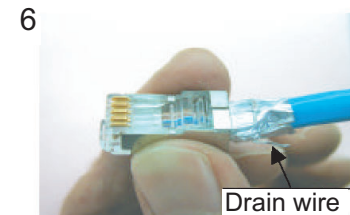

6 Insert the cable into the modular plug so that the folded part of the shield enters the modular plug. The drain wire must be on the tab side of the jack.



7 Using special crimping tool MPT5-8AS (PANDUIT CORP.), crimp the modular plug. Finally check the plug visually.

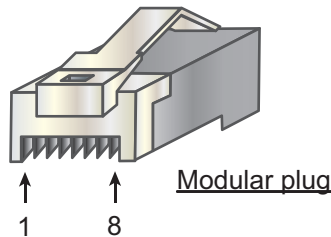

Modular plug

[Straight cable]

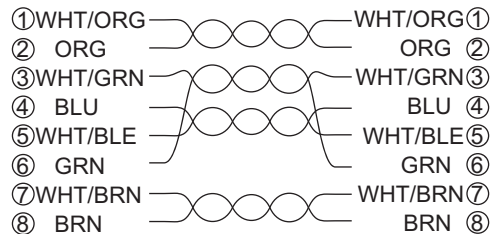

Fabrication of cables TTYCSLA-4, TYCSLA-7, TTYCSLA-1Q and TTYCSLA-1

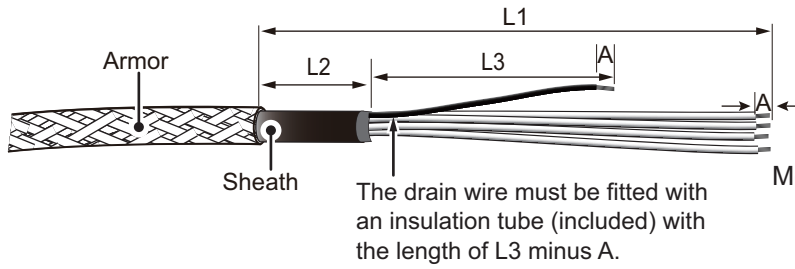

Measurements are displayed in mm

Unit	L1	L2	L3	A
FA-1701	*	80	80	6
FA-1702	130	80	60	6
FA-1703	170	100	80	9

Using the terminals supplied on the inside of the FA-1701, fit the drain wire of each TTYCSLA cable with a terminal, then attach the terminal to the inside of the FA-1701 (the same place it was situated originally).

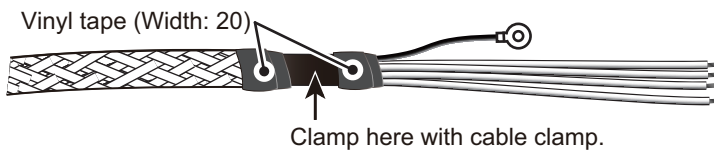

*: Length depends on installation configuration. When fabricating this cable, ensure enough slack is left to allow easy access for maintenance and service.

Note: L2 lengths displayed in the table above are the minimum recommended length. Adjust the length according to the installation configuration.

Fabrication of power cable DPYC-2.5

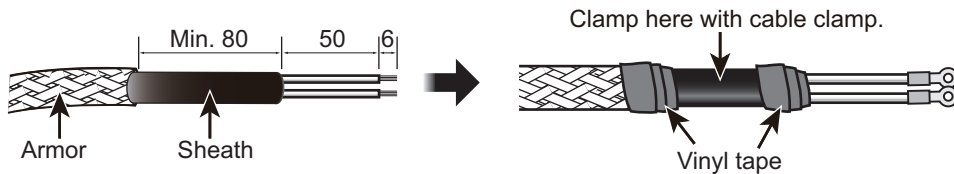

2.2.1 How to secure and waterproof exposed connections

All exposed connections between units should be secured and waterproofed using the procedure below.

1) Wrap the connection with self-vulcanizing tape.

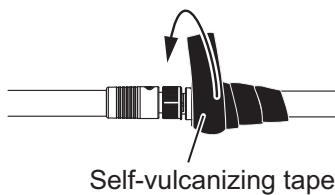

2) Wrap a second layer of self-vulcanizing tape in the opposite direction.

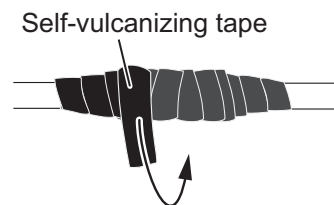

3) Wrap vinyl tape over the self-vulcanizing tape.

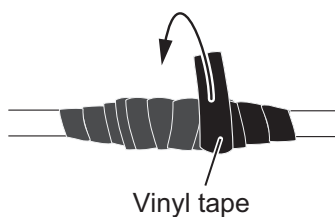

4) Wrap a second layer of vinyl tape in the opposite direction.

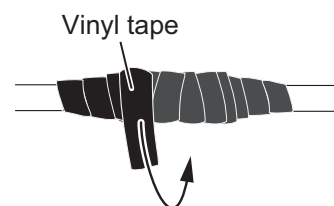

2.3 Unit Interconnection

The transponder unit (FA-1701), monitor unit (FA-1702) and the pilot plug unit (FA-1703) use different connectors for interconnection. See the figures below to fabricate the connections.

How to attach wires to the connectors

Transponder unit FA-1701
Terminal opener is located on rear of the FA-1701 cover.

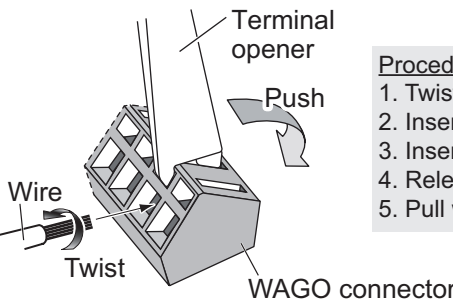

Procedure

1. Twist core.
2. Insert terminal opener and push.
3. Insert wire into hole. Be careful not to pinch the sheath.
4. Release terminal opener.
5. Pull wire to confirm it is correctly inserted.

Monitor unit FA-1702
Terminal opener is located inside cable clamp (rear cover).

Push downward.

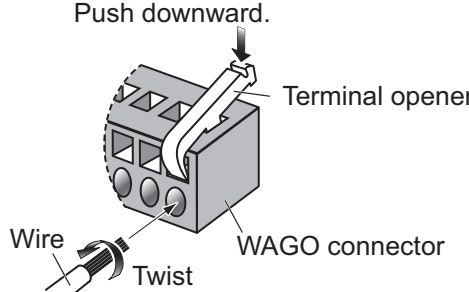

Procedure

1. Twist the cores.
2. Push the terminal opener downward.
3. Insert the wire to hole.
4. Remove the terminal opener.
5. Pull the wire to confirm that it is secure.

Pilot plug unit FA-1703
Use a flat head screwdriver to open the terminals.

Push downward.

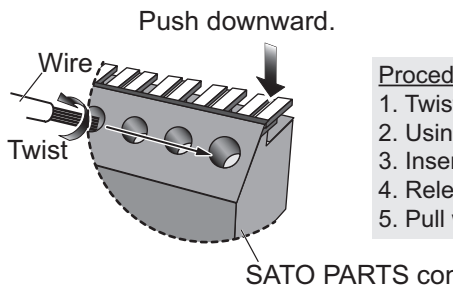

Procedure

1. Twist core.
2. Using a flat screw driver, push the terminal opener.
3. Insert wire into hole. Be careful not to pinch the sheath.
4. Release terminal opener.
5. Pull wire to confirm it is correctly inserted.

2.3.1 How to connect the FA-1702 monitor unit

1. Unfasten the four screws on the rear cable clamp, then remove the cable clamp to reveal the WAGO connector.

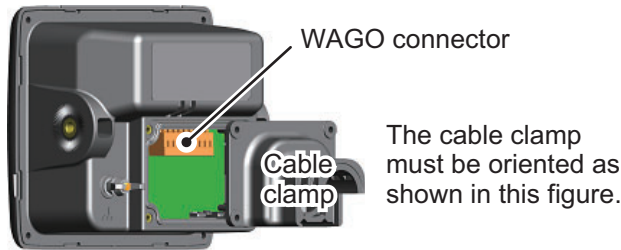

2. Unplug the WAGO connector from the FA-1702.
3. Pass the cable through the cable clamp.
Note: To maintain the IPx5 waterproof rating, the cable must be TTYCSLA-4 (or equivalent) with a diameter of $\phi 14.4 \pm 0.4$ mm.
4. Referring to the table below and the interconnection diagram at the back of this manual, connect the FA-1702 using the WAGO connector inside the unit.

WAGO Pin No.	Connection	WAGO Pin No.	Connection
1	P12V_P	6	TD-B
2	GND	7	RD-A
3	PON-H	8	RD-B
4	PON-C	9	Drain wire
5	TD-A		

5. Slide the cable clamp along the cable towards the FA-1702, then fasten the four screws which were removed at step 1. The cable clamp must be oriented as shown the figure above.
6. Secure the cable to the cable clamp with cable tie(s) (included). The location and number of cable tie(s) is different, depending on whether the cable assembly OP05-146-1, OP05-146-2, optional cable protection kit or waterproofing kit is installed. Refer to the figure below for the correct location and numbers.

Top view of cable clamp

When using the cable assembly OP05-146-1, OP05-146-2 or the cable protection kit (OP05-147)	When using the cable (TTYCSLA-4)	
	Without using the waterproofing kit (OP05-139)	With using the waterproofing kit (OP05-139)
With three cable ties	With two cable ties	With a single cable tie
<p>Secure the cable gasket also with a cable tie.</p>	<p>Wind cable ties through the slots.</p>	<p>Wind a cable tie outside of the cable clamp.</p>

2. WIRING

In cases where the WAGO connector is connected to the cable before the cable is passed through the cable clamp, the cable clamp can be adjusted to allow connection.

Note: Adjusting the cable clamp as outlined in the figure below voids the IPx5 waterproof rating of the clamp and the unit. To keep the IPx5 rating, remove the WAGO connector, then repeat the procedure above. When the following adjustment is done, the protection rating will be IPx2 even if any cable gasket is used.

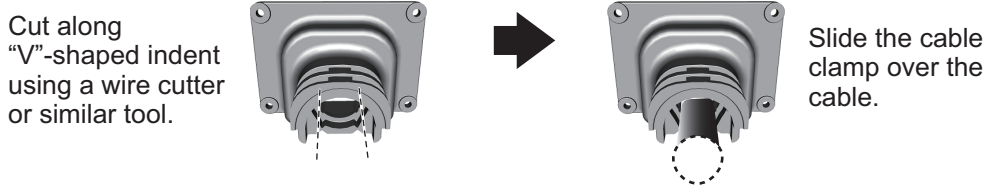

2.3.2 How to connect the FA-1701 transponder unit

Referring to the figure and table below, connect the FA-1701. The figure below also shows the recommended entry point for connected cables. (Based on a vessel configured to use all WAGO connection points.)

The WAGO connection points are individually marked on the TRX-PWR PC board.

No.	Connection point
1	COM6
2	LAN
3	COM5
4	COM4
5	COM3
6	COM2
7	COM1
8	DISP
9	DC_IN
10	SENSOR1
11	SENSOR2
12	SENSOR3
13	ALARM
14	BS (Blue Sign)
15	Silent

Cable entry #8 should be used for DISP cabling, regardless of vessel configuration, as the entry hole is larger than the other entry points.

Cable entry #2 should be used for LAN connection, regardless of vessel configuration, to avoid excess stress on the LAN cable.

Port	Description
COM1 to COM3	Long range communication device (Inmarsat C, etc.) or External display (Radar, ECDIS, NavNet 2, NavNet 3D), BEACON or Pilot Plug Unit
COM4 to COM6	Long range communication device (Inmarsat C, etc.) or External display (Radar, ECDIS, NavNet 2, NavNet 3D), Pilot Plug Unit, BEACON or Sensor (GNSS, Gyrocompass, Speed log, ROT)
DISPLAY	Connects to Monitor Unit FA-1702.
ALARM	Connects to on-board alarm system.

Port	Description
BS (Blue Sign)	Connects a Blue Sign device, a lighting device mounted on the bridge which gives off a blue light to warn oncoming vessels when the vessel is navigating a channel in the reverse direction.
SENSOR	GNSS, Gyrocompass, Speed log, ROT.

Note 1: The cable entry points (for the top row only) are protected from foreign material with small plastic spacers. Remove the spacers as required when connecting cables to the FA-1701.

All cables should be secured at the cable clamps (indicated as #1 through #15 in the figure above) using cable ties (included). The LAN cable in particular should be secured with the outer sheath of the LAN cable on the cable clamp.

2.3.3 How to connect the FA-1703 (Pilot Plug Unit, optional)

The FA-1703 is shipped with a flushmount panel attached. The flushmount panel can be removed if it is not required.

The example figures below show the FA-1703 without a flushmount panel.

1. Unfasten the four screws at the locations indicated with arrows in the figure below.

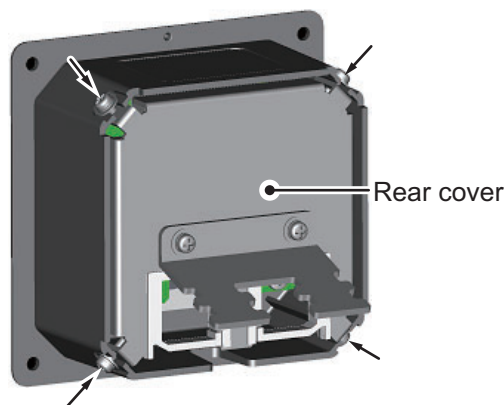

2. Remove the rear cover of the FA-1703. The 05P0895 board, with three SATO PARTS connectors, is exposed.

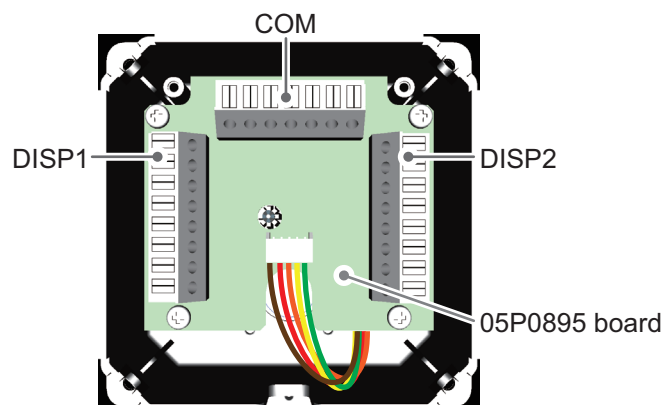

3. Referring to "Unit Interconnection" on page 2-4 and the interconnection diagram at the rear of this manual, connect the FA-1703.

2. WIRING

4. Pass the connected cables through the locking wire saddle on the rear cover, then fit the rear cover to the FA-1703.

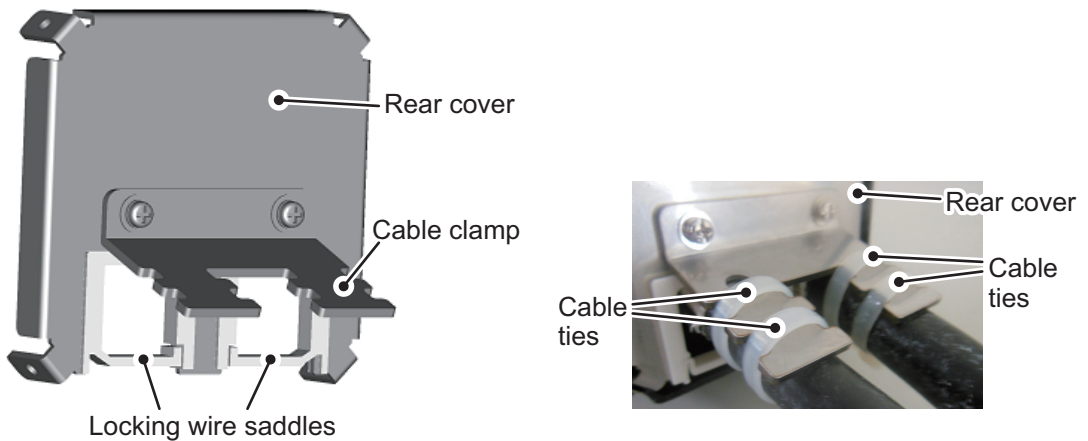

5. Fasten the four screws removed at step 1, then secure the connected cables to the cable clamp with cable ties.

2.4 How to Terminate COM Ports (For IEC 61162-1/2 signal)

When the output/input signal used is IEC61162-2 format, terminate at the DIP switch (S2, S3) as required. The DIP switch is located on the TRX-PWR board, see the figure below.

Note 1: Incorrect termination may cause communication errors.

Note 2: The factory default setting DIP switch S2 and S3 are shown in the figure below.

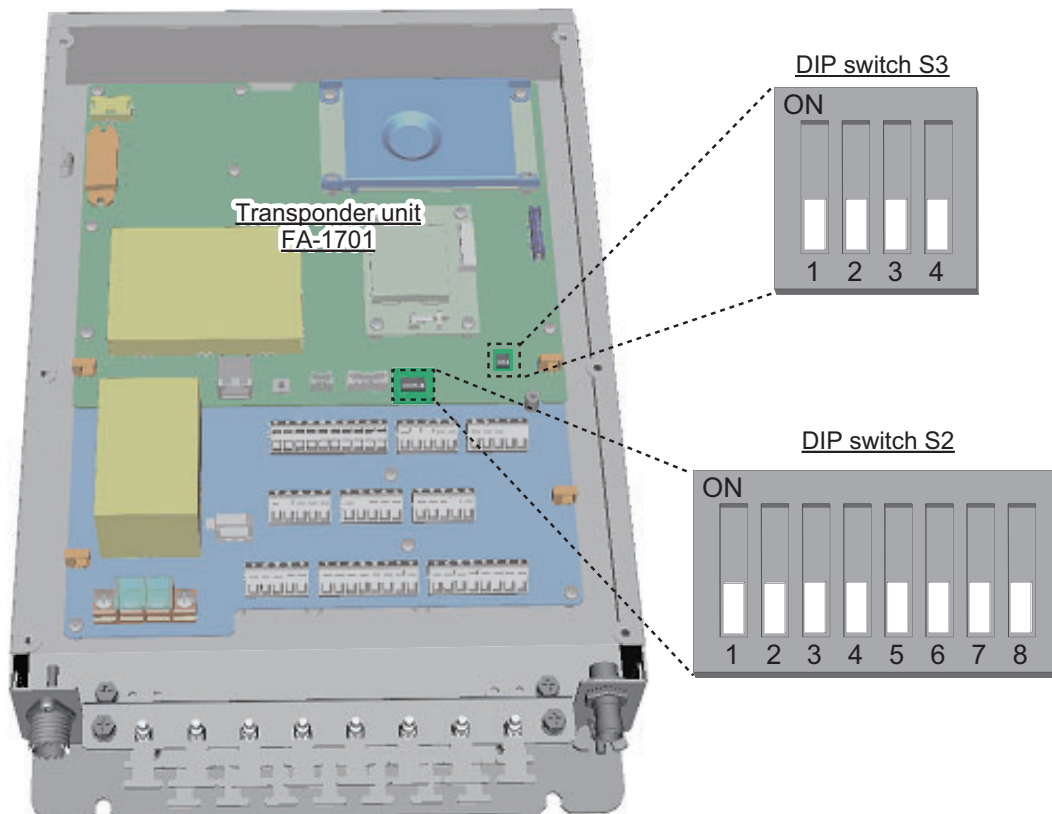

COM port	Termination
COM1	Set S2 #1 to ON.
COM2	Set S2 #2 to ON.

Note: S2 #3 to #8 are for technical personnel only. Do not change these settings.

COM port	Termination
COM3	Set S3 #1 to ON.
COM4	Set S3 #2 to ON.
COM5	Set S3 #3 to ON.
COM6	Set S3 #4 to ON.

Note: When using the COM ports as IEC61162-1, termination must be OFF.

Where the FA-1701 is part of a daisy chain, and is not the last unit in the daisy chain, the DIP switch for the daisy chained COM port must be OFF. Where the FA-1701 is the last unit in the daisy chain, do not change the DIP switch settings.

2.5 Connection of Ship’s Main and AC-DC Power Supply

The AC-DC power supply PR-241 is shipped ready for connection to a 100-230 VAC ship’s main.

Front panel

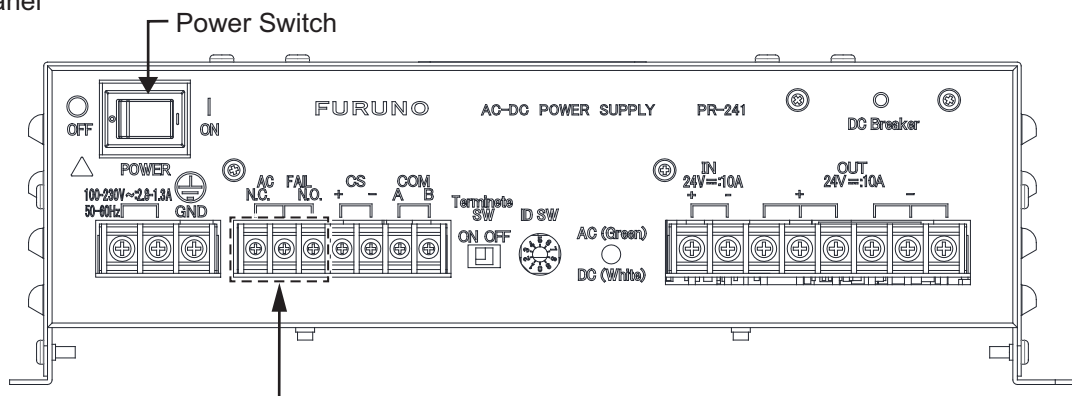

AC FAIL: Connect to Alarm system.

Output Setting: Normal Open → Connect to N.O. terminal (Right terminal)
 Normal Close → Connect to N.C. terminal (Left terminal)

2. WIRING

The AC-DC power supply PR-240 is shipped ready for connection to a 200-230 VAC ship's main. If the ship's main is 100 VAC-115 VAC, change the tap connection and terminal board connection as below. Attach label supplied as accessories to the front panel according to the ship's main.

Ship's main	Tap connection	Terminal board	Label
200-230 VAC	SEL 230 V	Below (a)	200-230 VAC 2.5-2.0 A 1φ, 50/60 Hz
100-115 VAC	SEL 115 V	Below (b)	100-115 VAC 4.0-3.5 A 1φ, 50/60 Hz

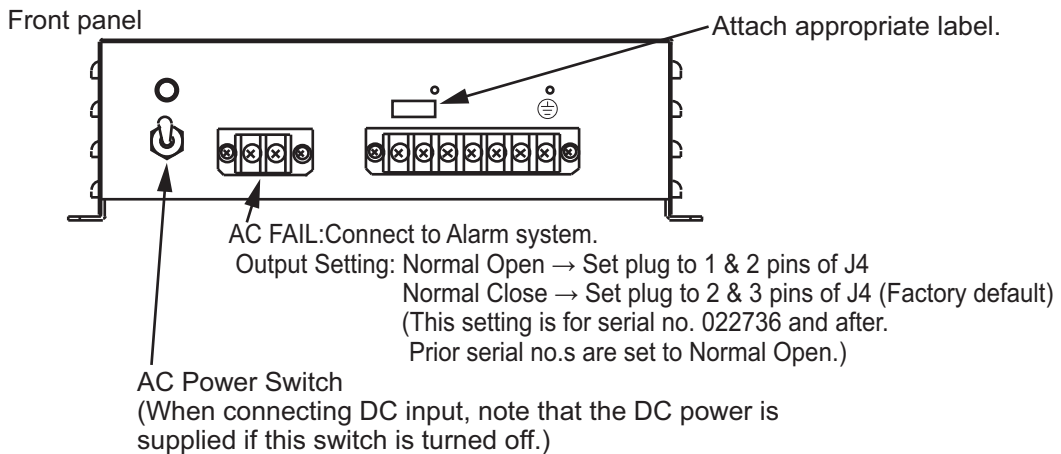
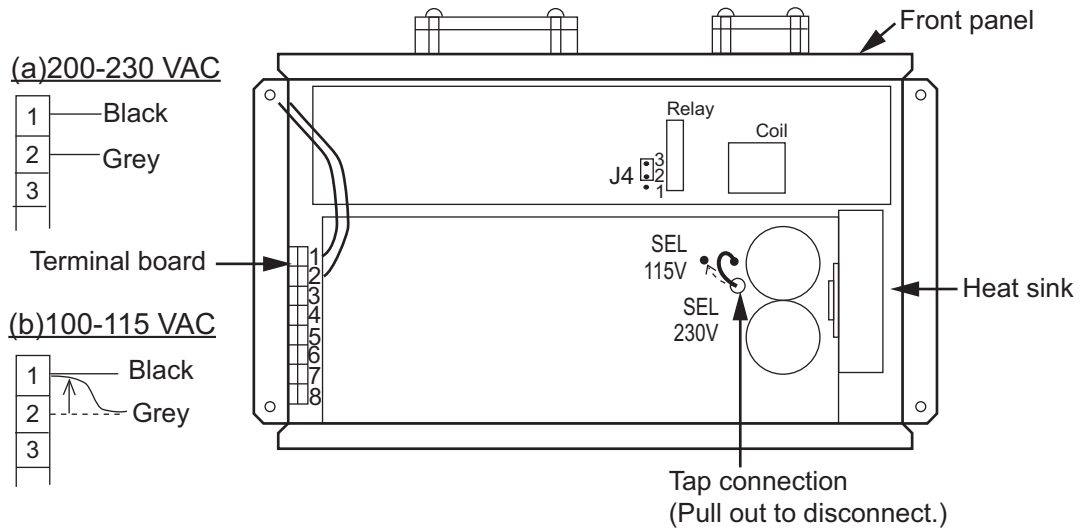
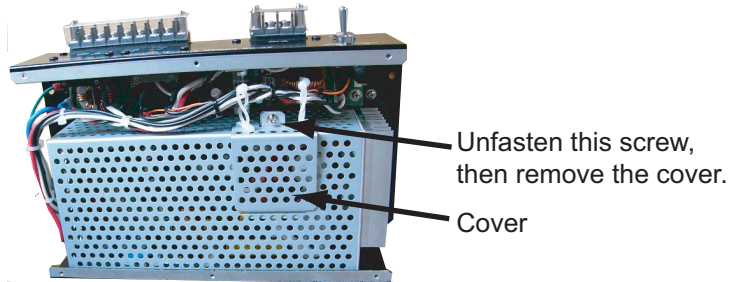

Note: The DC output load must be less than 8A.

3. SETTINGS AND ADJUSTMENTS

After installing the equipment, set up the own ship's static information (MMSI, IMO number, ship's name, call sign, ship and GNSS antenna position). Also, set up the I/O ports, port priority, network, pre-shared key.

How to access the [INITIAL SET] menu

The [INITIAL SET] menu can be accessed at any time, however settings are password-locked and require a qualified technician or dealer for password input.

1. Press the **MENU/ESC** key to open the menu.

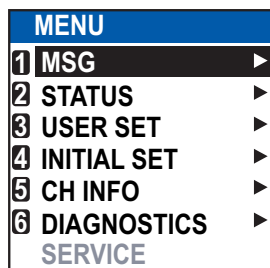

2. Select [INITIAL SET], then press the **ENT/ACK** key.
3. Select [EDIT], then press the **ENT/ACK** key. A pop up options window is displayed.

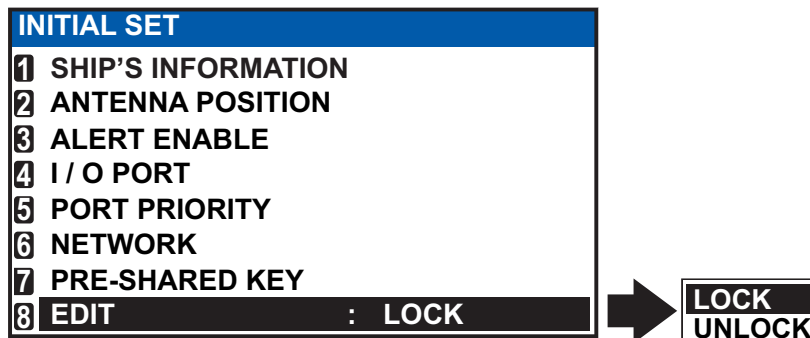

4. Select [UNLOCK], then press the **ENT/ACK** key. The password entry screen is displayed.

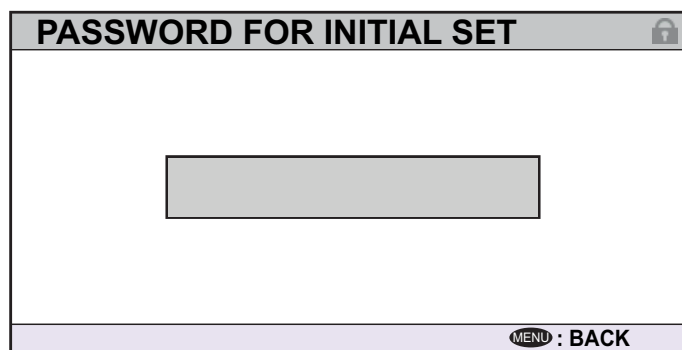

5. Input the password, then press the **ENT/ACK** key.

If the password is correct, the indication for [EDIT] reads "UNLOCK" and the [INITIAL SET] menu items can be edited. The lock icon, found on all settings screens, also changes to a blue colored open lock icon.

3.1 How to Set MMSI, IMO No., Name and Call Sign

This section covers the basic setup for CLASS A AIS systems. Inland AIS systems require several Inland AIS specific settings, outlined in section 3.2.

1. Access the [INITIAL SET] menu, following the procedure outlined in "How to access the [INITIAL SET] menu" on page 3-1.
2. Select [SHIP'S INFORMATION], then press the **ENT/ACK** key.
3. Select [MMSI], then press the **ENT/ACK** key to display the [MMSI] pop up window.

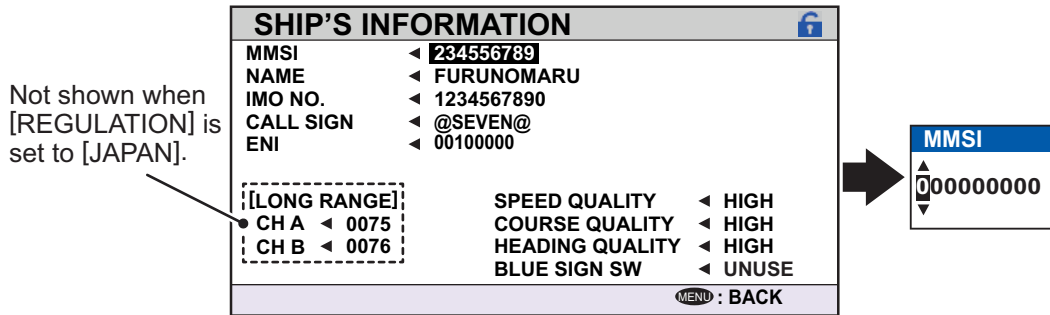

Note: [ENI], [SPEED QUALITY], [COURSE QUALITY], [HEADING QUALITY] and [BLUE SIGN SW] are Inland AIS settings. These items do not appear for other AIS modes. For Inland AIS settings, see section 3.2.

4. Use the arrow keys to set the [MMSI], then press the **ENT/ACK** key. The characters are cycled in the following order when ▲ is pressed: 1, 2 ... 9, 0, 1, 2... press ▼ to cycle through characters in the opposite direction. Press ► or ◀ to move the selection cursor.
5. Input the IMO number in a similar manner to MMSI.
IMO: Ten digits. If the IMO number has 8 digits, enter "0" twice followed by IMO number. If the ship has no IMO number, enter ten zeros. Inland AIS is fixed at "0".
6. For [NAME] and [CALL SIGN], the software keyboard is displayed when the item is selected.

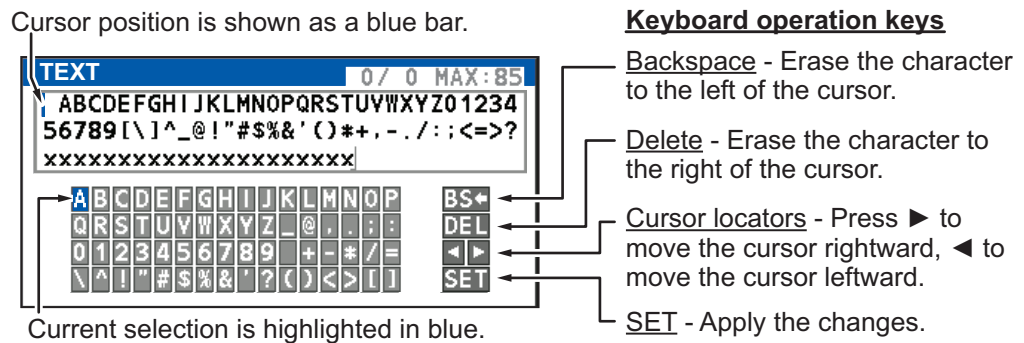

- 1) Referring to the figure above, press the arrow keys to select a character or keyboard operation.
 - 2) Press the **ENT/ACK** key to confirm your selection.
 - 3) Repeat steps 1 and 2 to complete the alphanumeric input.
 - 4) Select [SET], then press the **ENT/ACK** key.
7. After entering data, press the **DISP** key to close the menu.

Note: If you enter incorrect data, do the procedure from step 1.

3.2 Inland AIS Specific Settings

This section shows how to activate and set up the Inland AIS feature. The AIS activation key is obtained from the place of purchase.

3.2.1 How to activate the Inland AIS

Input your key number (received from dealer) to activate the Inland AIS.

1. Press the **MENU/ESC** key to open the menu.

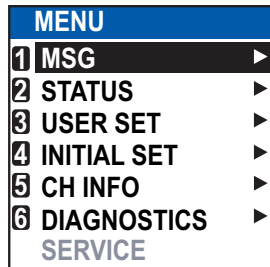

2. Select [USER SET] then press the **ENT/ACK** key.

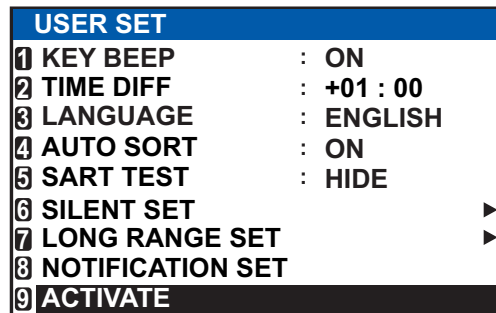

3. Select [ACTIVATE] then press the **ENT/ACK** key.

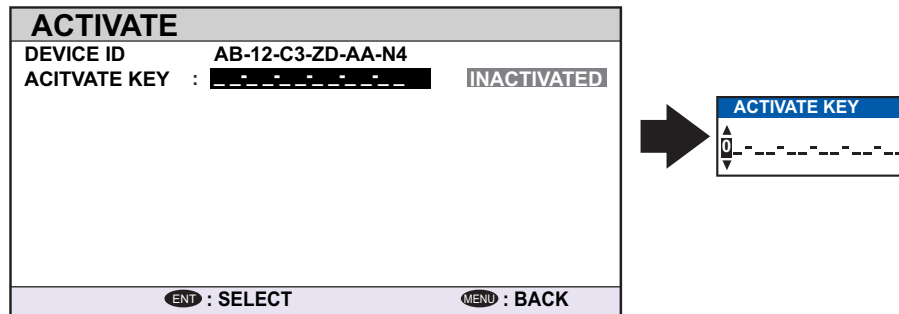

4. Press the **ENT/ACK** key to display the alphanumeric pop up window.
The characters are cycled in the following order when ▲ is pressed: 1, 2 ... 8, 9, A, B, C ... X, Y, Z, 1, 2... press ▼ to cycle through characters in the opposite direction. Press ▶ or ◀ to move the selection cursor.
5. Input the activation key, then press the **ENT/ACK** key.

If you entered the activation key correctly, the indication "ACTIVATED. SYSTEM WILL RESTART" appears then the system is automatically restarted.

3.2.2 How to set blue sign status

Blue sign (a day-sign), which in combination with a white flashing light, must be shown if you are sailing on the port-side shore (against traffic direction).

1. Access the INITIAL SET menu, following the procedure outlined in "How to access the [INITIAL SET] menu" on page 3-1.
2. Select [SHIP'S INFORMATION] then press the **ENT/ACK** key.
Note: [SHIP TYPE] is not displayed and the [IMO NO.] for your vessel is displayed as "0" when using [INLAND] mode.
3. Select [BLUE SIGN SW], then press the **ENT/ACK** key. A pop up options window is displayed.

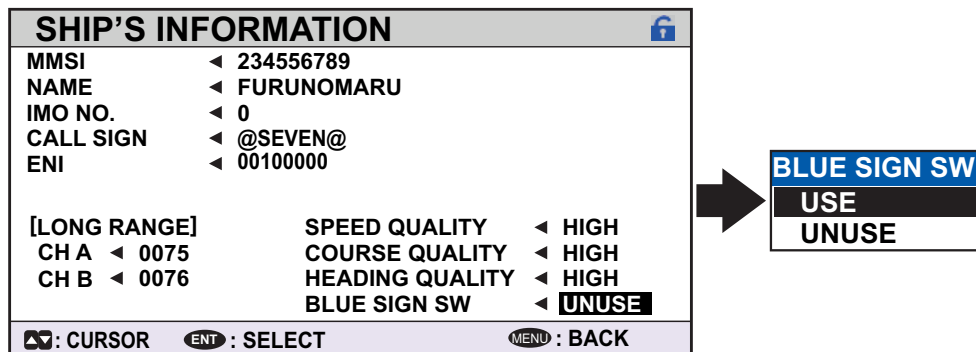

4. Select [UNUSE] (not in use) or [USE] (in use) as applicable, then press the **ENT/ACK** key.

3.2.3 Other inland AIS specific settings

Inland AIS requires the following additional settings:

ENI

1. Select [ENI], then press the **ENT/ACK** key to display the [ENI] pop up window.
2. Use the arrow keys to set the [ENI], then press the **ENT/ACK** key. The characters are cycled in the following order when ▲ is pressed: 1, 2 ... 9, 0, 1, 2... press ▼ to cycle through characters in the opposite direction. Press ► or ◀ to move the selection cursor.

Sensor quality

Set [SPEED QUALITY], [COURSE QUALITY] and [HEADING QUALITY] as follows:

1. Select [SPEED QUALITY], then press the **ENT/ACK** key to display the [SENSOR QUALITY (SPEED)] pop up window.
2. Select the [HIGH] or [LOW] as appropriate, then press the **ENT/ACK** key.
Select [HIGH] where there is three or more referenced sensors, giving a higher quality reading.
Select [LOW] where there is only one or two sensors, giving a reading which may require periodic adjustment.
3. Set [COURSE QUALITY] and [HEADING QUALITY] in the same manner.

3.3 How to Set GNSS Antenna Position

Set the antenna position using this procedure. For INLAND AIS users, this procedure must be done in both INLAND mode and SOLAS mode.

1. Access the [INITIAL SET] menu, following the procedure outlined in "How to access the [INITIAL SET] menu" on page 3-1.
2. Select [ANTENNA POSITION], then press the **ENT/ACK** key. The settings screen for [ANTENNA POSITION] is displayed.

ANTENNA POSITION		
[SHIP SIZE]	LENGTH	BEAM
:	0m	0m
[ANT POSN]	Y	X
1 INTERNAL :	0m	0m
2 EXTERNAL :	0m	0m
[ANT POSN]	↕A,B↕	↔C,D↔
1 INTERNAL ◀	00,00	00,00
2 EXTERNAL ◀	00,00	00,00
⏏ : CURSOR ⏎ : SELECT ⏪ : MENU : BACK		

3. The [LENGTH] option is selected, press the **ENT/ACK** key to input the vessel length. The available range for length is 0 m to 800 m. Press the **ENT/ACK** key to apply the setting.
4. Select [BEAM], then press the **ENT/ACK** key to input the vessel beam. The available range for beam is 0 m to 100 m. Press the **ENT/ACK** key to apply the setting.

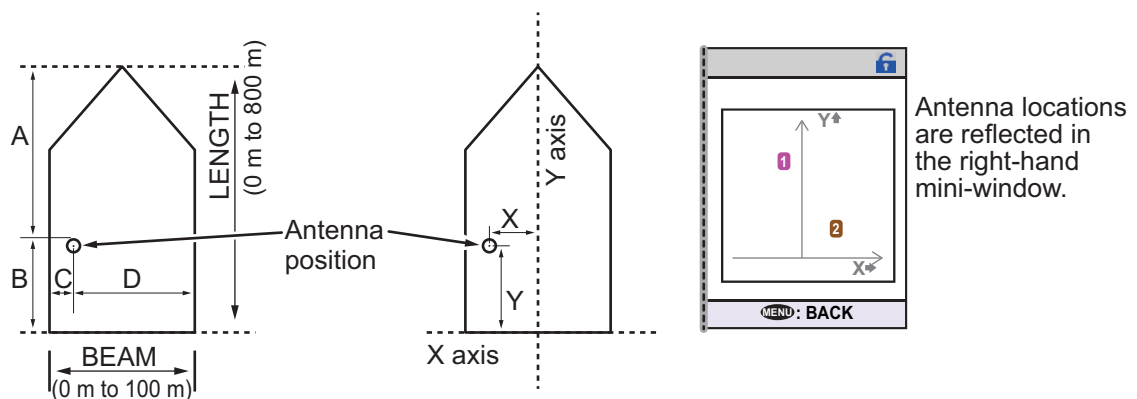

5. Select the Y indication for the internal antenna, then press the **ENT/ACK** key. A settings pop up window is displayed. The pop up shows the available setting range at the bottom. The Y axis coordinates are calculated from the stern of the vessel. The setting range varies depending on the vessel's dimensions.
6. Set the bow-stern position for the antenna, then press the **ENT/ACK** key.
7. Select the X indication for internal antenna, then press the **ENT/ACK** key. The X coordinates are calculated from the center of the vessel. Negative settings give a port-side positioning, positive settings give a starboard-side positioning.
8. Set the port-starboard position for the antenna, then press the **ENT/ACK** key.
9. Set the position for the external antenna, then press the **ENT/ACK** key. A settings pop up window is displayed. The pop up shows the available setting range at the bottom.

Note: The settings for the antenna position are reflected at the bottom of the screen, in gray, as [A,B] for bow-stern positioning and [C,D] for port-starboard positioning, and the antenna numbers are also shown in the right-hand mini-window.
10. Press the **MENU/ESC** key to return to the [INITIAL SET] menu.

3.4 How to Enable or Disable Alerts

You can enable or disable alerts from the [ALERT ENABLE] menu. Disabling an alert in this menu will disable all related alerts for the disabled alert.

Note: All alerts are set to [ENABLE] by default.

1. Access the [INITIAL SET] menu, following the procedure outlined in "How to access the [INITIAL SET] menu" on page 3-1.
2. Select [ALERT ENABLE], then press the **ENT/ACK** key.

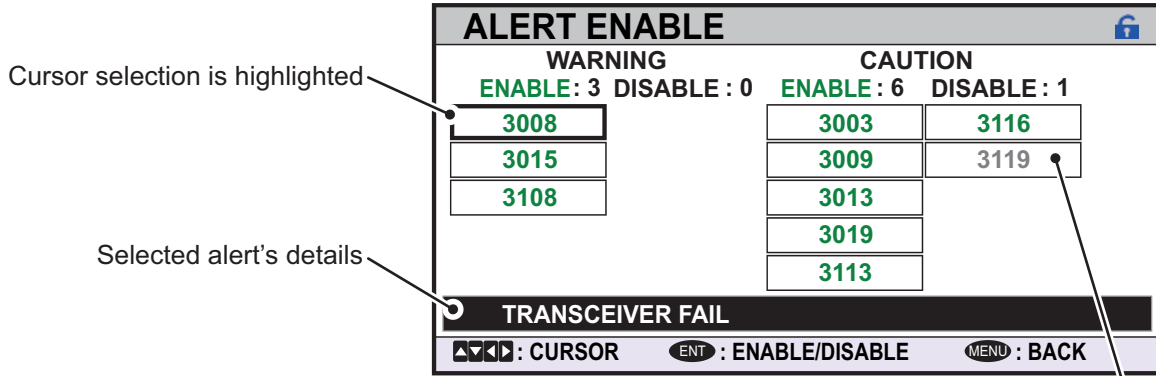

Disabled alerts are displayed in gray.

Note: This display is when Alert Mode is set to Alert IF2.

3. Select an alert, then press the **ENT/ACK** key to enable or disable the alert. Enabled alerts are displayed in green color text, disabled alerts are displayed in gray color text.
4. Press the **MENU/ESC** key to return to the [INITIAL SET] menu.

3.5 How to Set Up the I/O Ports

1. Access the [INITIAL SET] menu, following the procedure outlined in "How to access the [INITIAL SET] menu" on page 3-1.
2. Select [I/O PORT], then press the **ENT/ACK** key.

I / O PORT		
PORT	MODE	SPEED
COM1	: EXT DISPLAY	38400baud
COM2	: EXT DISPLAY	38400baud
COM3	: EXT DISPLAY	38400baud
COM4	: EXT DISPLAY	38400baud
COM5	: EXT DISPLAY	38400baud
COM6	: EXT DISPLAY	38400baud
SENSOR1	: SENSOR	4800baud
SENSOR2	: SENSOR	4800baud
SENSOR3	: SENSOR	4800baud

: CURSOR : SELECT : BACK

Note: The figure above shows the default settings for all ports.

The available port settings are outlined in the table on the following page.

PORT	MODE	SPEED (baud)
COM1	EXT DISPLAY	4800, 38400
	PILOT PLUG	38400
	LONG RANGE	4800, 38400
	BEACON	4800
	MONITOR	57600
	DISABLE	-
COM2 to COM3	Same as COM1.	Same as COM1.
COM4	EXT DISPLAY	4800, 38400
	PILOT PLUG	38400
	LONG RANGE	4800, 38400
	SENSOR	4800, 38400
	BEACON	4800
	MONITOR	57600
	DISABLE	-
COM5 to COM6	Same as COM4.	Same as COM4.
SENSOR1	SENSOR	Fixed at 4800
	DISABLE	-
SENSOR2 & SENSOR3	Same as SENSOR1.	Same as SENSOR1.

Note 1: When [MODE] is set to [PILOT PLUG], [BEACON] or [MONITOR], speed settings are fixed at the default setting.

Note 2: For detailed information on data format and related speeds, see "DIGITAL INTERFACE" on page AP-2.

Mode definitions

MODE	Definition
EXT DISPLAY	External display (Radar, ECDIS, Pilot plug, etc.).
PILOT PLUG	External display (Radar, ECDIS, Pilot plug, etc.). Heading and rate of turn are output.
LONG RANGE	Long range communication device (Inmarsat C, etc.).
SENSOR	GNSS, Gyrocompass, ROT, etc.
MONITOR	For FA-1702 Monitor Unit.
BEACON	For Beacon Receiver.

3. SETTINGS AND ADJUSTMENTS

MODE	Definition
DISABLE	Disable the port.

3.5.1 How to set port priority

1. Access the [INITIAL SET] menu, following the procedure outlined in "How to access the [INITIAL SET] menu" on page 3-1.
2. Select [PORT PRIORITY], then press the **ENT/ACK** key.

Selected item is highlighted in reverse video.

PORT PRIORITY			
PRIORITY	LL/COG/COG	HDG	ROT
1st	SENSOR3	SENSOR3	SENSOR3
2nd	SENSOR2	SENSOR1	SENSOR1
3rd	SENSOR3	SENSOR2	SENSOR2
4th	COM4	COM6	COM6
5th	COM5	COM4	COM4
6th	COM6	COM5	COM5
7th	LAN	LAN	LAN

: CURSOR
 : SELECT
 : BACK

3. Select the sensor whose priority you want to adjust, then press the **ENT/ACK** key. The [SENSOR PORT] pop up window is displayed.
4. Select the appropriate port, then press the **ENT/ACK** key.
5. Repeat step 3 to step 4 for other port priorities.
6. Press the **MENU/ESC** key to return to the [INITIAL SET] menu.

SENSOR PORT
SENSOR1
SENSOR2
SENSOR3
COM4
COM5
COM6
LAN

3.6 Network Set Up

The procedure for network setup differs depending on the setting for [NW PROTOCOL]. Follow the procedure which is appropriate for your settings; either [450] (IEC61162-450 compliant) or [NAVNET]. (Refer to "How to set the network protocol" on page 3-15.)

When [450] (IEC61162-450) is selected

1. Access the [INITIAL SET] menu, following the procedure outlined in "How to access the [INITIAL SET] menu" on page 3-1.
2. Select [NETWORK], then press the **ENT/ACK** key.

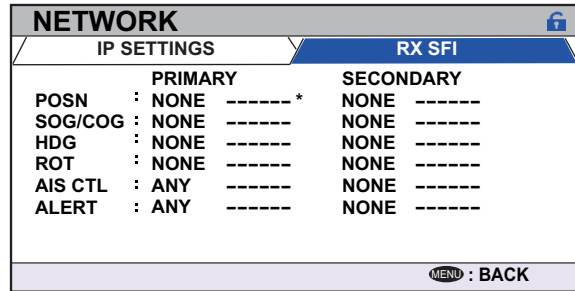
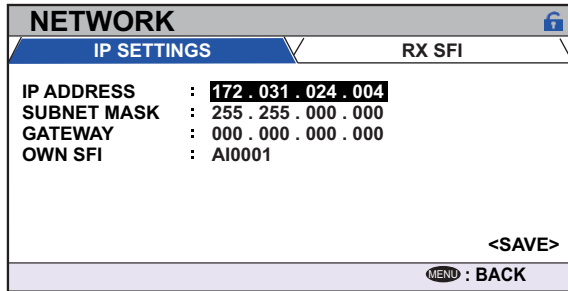

*: XXYYYY (X: A to Z, YYYY: 0000 to 9999)

Settings screens for [450]

3. [IP ADDRESS] is selected. Press the **ENT/ACK** key to show the IP address settings pop up window.
4. Set the IP address, then press the **ENT/ACK** key.
5. Select and set [SUBNET MASK], [GATEWAY] and [OWN SFI] in a similar fashion. **Note:** Be sure to use an SFI not used by other devices in the shipboard network.
6. Press ◀ or ▶ to display [RX SFI] tab.

The [RX SFI] tab is for selecting the data source on the network for each item. Up to two sensors can be selected as the data source ([PRIMARY] and [SECONDARY]). The sensor which is set as [PRIMARY] is prioritized.

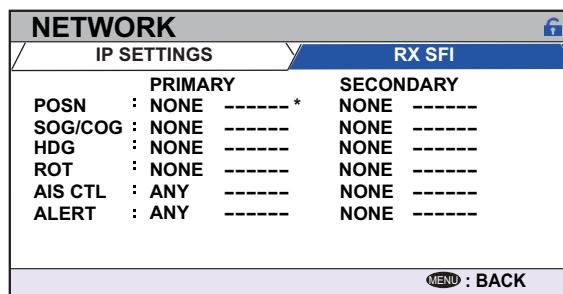

*: XXYYYY (X: A to Z, YYYY: 0000 to 9999)

- [POSN]: Data source for position
 - [SOG/COG]: Data source for Speed Over the Ground and Course Over the Ground
 - [HDG]: Data source for Heading
 - [ROT]: Data source for the Rate Of Turn
 - [AIS CTL]: Data source for AIS Control
 - [ALERT]: Data source for alert
7. Select [GROUP] of [POSN] - [PRIMARY] from [NONE] and [SFI]. **Note:** There are other options for the [GROUP] of other items.

3. SETTINGS AND ADJUSTMENTS

The meanings of [GROUP] are as follows.

[NONE]: Does not receive data from the sensors.

[SFI]: Receives data from the sensor which has the SFI set on [-----] ([SFI]).

When part of a LAN network, the FA-170, may receive data for the same item from several sources, which can result in unstable calculations. For stable calculations, set the [SFI] for the sensor to be used as the fixed data source.

[ANY]: Receives data from any connected sensor.

8. If [SFI] was selected, press ▼ to move the cursor to [-----] ([SFI]), then set the SFI for the sensor to receive data from. If [NONE] was selected, go to the next step in this procedure.
9. Press ▼ to move the cursor to [POSN] - [SECONDARY] and select the [GROUP] from [NONE] and [SFI].
10. If [SFI] was selected, press ▼ to move the cursor to [-----] ([SFI]), then set the SFI for the sensor to receive data from. If [NONE] was selected, go to the next step in this procedure.
11. Repeat step 7 to 10 for other items as required.
12. Confirm the settings on the [IP ADDRESS] tab are correct, then select [<SAVE>] and press the **ENT/ACK** key. A confirmation pop up is displayed.
Note: If no changes are made to the settings on [IP ADDRESS] tab, [<SAVE>] is not selectable.
13. Select [NO] to change the settings further. Select [YES] to accept the new settings, the unit now shuts down automatically to apply the new settings. After the unit shuts down, press the power key to restart the unit.

When [NAVNET] is selected on [NW PROTOCOL]

1. Access the [INITIAL SET] menu, following the procedure outlined in "How to access the [INITIAL SET] menu" on page 3-1.
2. Select [NETWORK], then press the **ENT/ACK** key.

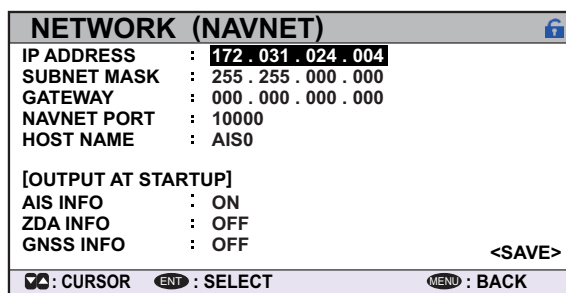

NAVNET network settings screen.

3. [IP ADDRESS] is selected. Press the **ENT/ACK** key to show the IP address settings pop up window.
4. Set the IP address, then press the **ENT/ACK** key.
5. Select and set [SUBNET MASK] and [GATEWAY] in a similar fashion.
6. Select [NAVNET PORT], then press the **ENT/ACK** key.
7. Input the NavNet port which this unit is connected to, then press the **ENT/ACK** key.
8. Select [HOST NAME], then press the **ENT/ACK** key.
9. Input the name for this unit within the NavNet network, then press the **ENT/ACK** key.

10. Select [AIS INFO], then press the **ENT/ACK** key.
11. Select [ON] to enable AIS data output to the NavNet network when this unit is turned on. Select [OFF] to disable AIS data output when this unit is turned on.
12. Set [ZDA INFO] and [GNSS INFO] in the same manner as [AIS INFO].
 [AIS INFO]: Turns on/off the output of AIS data.
 [ZDA INFO]: Turns on/off the output of ZDA sentence (current date and time).
 [GNSS INFO]: Turns on/off the position data.
13. Confirm the settings are correct, then select [<SAVE>] and press the **ENT/ACK** key. A confirmation pop up is displayed.
Note: If no changes are made to the settings, [<SAVE>] is not selectable.
14. Select [NO] to change the settings further. Select [YES] to accept the new settings, the unit now shuts down automatically to apply the new settings. After the unit shuts down, press the power key to restart the unit.

3.7 How to Set the PRE-SHARED Key



The Pre-shared key is a password that allows you to set the Ship's name, Call sign, GNSS antenna position and so on from the external equipment. Appropriate settings of pre-shared key is essential to reflect the settings from the external equipment.

The pre-shared key is set from the [MENU] → [INITIAL SET] → [PRE-SHARED KEY] menu. A password is required to check and change the settings of [PRE-SHARED KEY] menu.

The default password is "0000". When changing the password, change it to the one which can be remembered by the ship's captain and the relevant crew.

1. Select [INITIAL SET] menu, then select [PRE-SHARED KEY] menu and press **ENT/ACK** key.
2. Select the asterisk marks of [EDIT PASSWORD] menu and press **ENT/ACK** key. [INPUT PASSWORD] pop-up menu appears.
3. When setting the password for the first time, enter the default password "0000" and press **ENT/ACK** key. Use ► or ◀ key to move the cursor, and use ▲ or ▼ key to change the number. When the password is correctly entered, the lock icon will be changed to show the unlocked status.

PRE - SHARED KEY	
EDIT PASSWORD : ****	[CHANGE PASSWORD] NEW : **** CONFIRM : ****
KEY : *****	
▲ : CURSOR ENT : SELECT MENU : BACK	

 Locked status (Not editable)
 Unlocked status (Editable)

3. SETTINGS AND ADJUSTMENTS

- Press ▼ or ► to select [NEW] entry field and press **ENT/ACK** key. A pop-up window to set the new password appears.

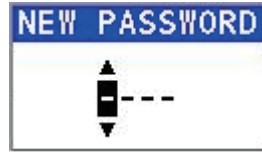

- Enter the new password (four digits) and press **ENT/ACK** key. Each digit can be from 0 to 9. Use ► or ◀ key to move the cursor, and use ▲ or ▼ key to change the number. If not setting the new password, proceed with step 8.
- Press ▼ or ► to select [CONFIRM] entry field and press **ENT/ACK** key. A pop-up window to confirm the new password appears.



- Enter the new password set in the step 5 and press **ENT/ACK** key.

When the new password is confirmed

[PRE-SHARED KEY] menu is locked and the lock icon will change to show the locked status. To proceed with the setting of [PRE-SHARED KEY], repeat step 2 and 3, then unlock the setting of [PRE-SHARED KEY].

When the new password was not confirmed

The unit release two short beeps to indicate that the passwords do not match. Repeat steps 4 to 6 and set the correct password.

- Select [KEY] and press **ENT/ACK** key.

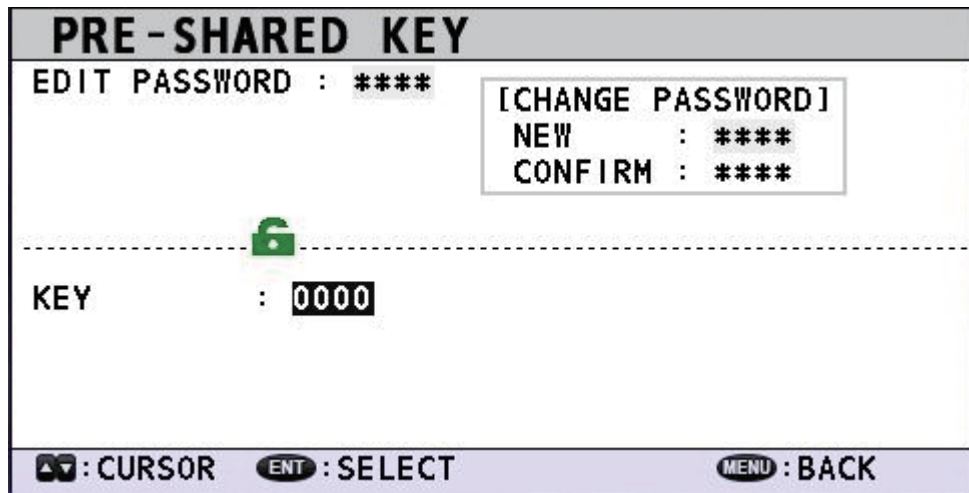

- Software keyboard appears. Enter [KEY] to set the pre-shared key (password) which will be shared with the external equipment. 16 characters is the maximum.
- Close the menu by pressing the **MENU** key.

3.8 SERVICE Menu Operations

The [SERVICE] menu is password protected. Contact FURUNO for password details.

[SERVICE] menu access is required to setup the following items:

- [ALERT MODE] settings
- Network protocol settings
- Restore Factory settings etc.

SERVICE	
1	CH SET ▶
2	AIS SET ▶
3	ALERT SET ▶
4	FACTORY SET ▶
5	OTHER SET ▶
6	INITIALIZE ▶
7	TEST ▶
8	MAINTENANCE ▶
9	DEVELOPER ▶

3.8.1 How to access the SERVICE menu

1. From the [MAIN] menu, select [SERVICE], then press the **ENT/ACK** key. The password input pop up window appears.
2. Input the password then press the **ENT/ACK** key.

3.8.2 How to hide CPA/TCPA

Factory default settings show CPA/TCPA. You can hide (or re-show) the CPA/TCPA indications, by doing the following:

1. Access the [SERVICE] menu referring to the procedure outlined at the start of this section.
2. Select [AIS SET], then press the **ENT/ACK** key.
3. Select [CPA/TCPA], then press the **ENT/ACK** key. The options pop up window appears.
4. Select [SHOW] or [HIDE] as appropriate, then press the **ENT** key.

AIS SET	
1	REGULATION : INT'L
2	OUTPUT VDM : NORMAL
3	CPA/TCPA : SHOW
4	DATA PROTECT : <input type="button" value="SHOW"/>
	<input type="button" value="HIDE"/>

5. Press the **MENU/ESC** key to return to the [INITIAL SET] menu, or press the **DISP** key to close all open menus.

3.8.3 How to set the alert mode

The alert mode can be set according to the vessel's configuration. The available alert modes are: [LEGACY ED.1], [LEGACY ED.2], [ALERT IF1] and [ALERT IF2].

1. Access the [SERVICE] menu referring to the procedure outlined at the start of this section.
2. Select [ALERT SET], then press the **ENT/ACK** key.
3. Select [ALERT MODE], then press the **ENT/ACK** key.
Note: The [OPERATIONAL] setting is for technical personnel only. Do not change this setting.

3. SETTINGS AND ADJUSTMENTS

4. Select the appropriate [ALERT MODE] setting, then press the **ENT/ACK** key. Select [ALERT IF1] for vessels configured with AMS, [ALERT IF2] for vessels configured with BAM.

ALERT SET	
1 ALERT MODE	: LEGACY ED.2
2 OPERATIONAL	: LEGACY ED.1
3 CLUSTER	: LEGACY ED.2
4 CAM TALKER	: ALERT IF1
	: ALERT IF2

5. Press the **MENU/ESC** key to return to the [INITIAL SET] menu, or press the **DISP** key to close all open menus.

3.8.4 How to set the Cluster menu

The [CLUSTER] menu is available only when the [ALERT MODE] is set to [ALERT IF2] (when connecting to BAM). The cluster to which this equipment belongs can be specified with this menu.

1. Access the [SERVICE] menu referring to the procedure outlined at the start of this section.
2. Select [ALERT SET], then press the **ENT/ACK** key.
3. Select [CLUSTER], then press the **ENT/ACK** key.

ALERT SET	
1 ALERT MODE	: LEGACY ED.2
2 OPERATIONAL	: ACKED
3 CLUSTER	: NAV
4 CAM TALKER	: NAV
	: COM
	: NONE

4. Select the appropriate [CLUSTER] setting, then press the **ENT/ACK** key.
5. Press the **MENU/ESC** key to return to the [INITIAL SET] menu, or press the **DISP** key to close all open menus.

3.8.5 How to set the network protocol

Set the LAN network protocol according to the vessel's on-board network. [NAVNET] protocol should be used where a NavNet series unit is the LAN network hub. Select [450] for all other LAN networks.

1. Access the [SERVICE] menu referring to the procedure outlined at the start of this section.
2. Select [OTHER SET], then press the **ENT/ACK** key.
3. Select [NW PROTOCOL], then press the **ENT/ACK** key.

Note: The rest of the [OTHER SET] menu items are for technical personnel only. Do not change these setting.



4. Select the appropriate protocol, then press the **ENT/ACK** key. A confirmation pop up is displayed.
5. Select [YES] to accept the new setting or [NO] to cancel and return to the options. Selecting [YES] will restart the unit.

3.8.6 How to restore factory settings

This procedure resets the units to factory settings.

Be sure to set all appropriate settings from the [INITIAL SET] menu after completing this procedure.

1. Access the [SERVICE] menu referring to the procedure outlined at the start of this section.
2. Select [INITIALIZE], then press the **ENT/ACK** key.
3. Select [RESTORE FACTORY SET], then press the **ENT/ACK** key. The confirmation pop up window shown below-right is displayed.

Note: The rest of the [INITIALIZE] menu items are for technical personnel only. Do not change these settings.

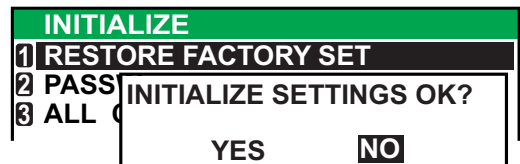

4. Select the [YES] or [NO] as appropriate, then press the **ENT/ACK** key.
 [YES]: Accept the new settings and restart the unit.
 [NO]: Cancel and return to the options.